



TECHNICAL DESCRIPTION



MD 500E HELICOPTER

MD Helicopters, Inc.
4555 E. McDowell Rd.
Mesa, AZ 85215
www.mdhelicopters.com
sales@mdhelicopters.com

MISSION PROVEN, CHALLENGE READY

THIS PAGE INTENTIONALLY LEFT BLANK

TECHNICAL DESCRIPTION

MD 500E HELICOPTER

MD Helicopters, Inc.
4555 E. McDowell Rd
Mesa, Arizona
www.mdhelicopters.com

This Technical Description includes information and intellectual property that is the property of MD Helicopters, Inc. (MDHI). It provides general information for evaluation of the design, equipment, and performance of the MD 500E helicopter. The information presented in this Technical Description does not constitute an offer and is subject to change without notice. This proprietary information, in its entirety, shall not be duplicated, used, or disclosed—directly or indirectly, in whole or in part—for any purpose other than for evaluation. MD Helicopters, Inc. reserves the right to revise this Technical Description at any time



REPORT NO.: MD14022809-500ETD
NO. OF PAGES: 52

Use or disclosure of data in this Technical Description is subject to the restriction on the cover page of this document.

ATTACHMENTS: None

| Revision | By | Approved | Date | Pages and/or Paragraphs Affected |
|-----------------|-----------|-----------------|-------------|---|
| New | BAH | | 28-Feb-14 | All (Initial Issue) |



Contents

| | | |
|-----------|---|-----------|
| 1. | FOREWORD | 1 |
| 2. | KEY ADVANTAGES AND FEATURES..... | 3 |
| 3. | CERTIFICATION | 5 |
| 4. | DIMENSIONS, WEIGHT, AND MISSION CONFIGURATION | 7 |
| 4.1 | EXTERNAL DIMENSIONS..... | 7 |
| 4.2 | INTERNAL DIMENSIONS..... | 7 |
| 4.3 | WEIGHT | 9 |
| 4.4 | CONFIGURATIONS | 9 |
| 5. | MD 500E SINGLE-ENGINE HELICOPTER..... | 11 |
| 5.1 | SYSTEM DESCRIPTION | 11 |
| 5.2 | STANDARD EQUIPMENT | 13 |
| 5.3 | MD 500E OPTIONAL EQUIPMENT | 14 |
| 5.4 | FUSELAGE..... | 15 |
| 5.5 | EXTERIOR | 17 |
| 5.6 | EXTERNAL LIGHTING | 17 |
| 5.7 | INTERIOR..... | 18 |
| 5.7.1 | <i>Cockpit.....</i> | <i>18</i> |
| 5.7.2 | <i>Cabin Compartment.....</i> | <i>18</i> |
| 5.7.3 | <i>Engine Compartment.....</i> | <i>18</i> |
| 5.8 | SYSTEMS | 19 |
| 5.8.1 | <i>Fuel System.....</i> | <i>19</i> |
| 5.8.2 | <i>Propulsion System.....</i> | <i>19</i> |
| 5.8.3 | <i>Drive System</i> | <i>20</i> |
| 5.8.4 | <i>Rotor System.....</i> | <i>20</i> |
| 5.8.5 | <i>Inlet Barrier Filter System.....</i> | <i>22</i> |
| 5.8.6 | <i>Flight Control System.....</i> | <i>22</i> |
| 5.8.7 | <i>Electrical System</i> | <i>23</i> |
| 5.8.8 | <i>Environmental Control System</i> | <i>23</i> |
| 5.8.9 | <i>Monitoring Instrumentation</i> | <i>24</i> |
| 5.8.10 | <i>Caution / Warning Annunciators</i> | <i>24</i> |
| 5.8.11 | <i>Avionics / Communications.....</i> | <i>24</i> |
| 6. | PERFORMANCE SPECIFICATIONS | 27 |
| 6.1 | MD 500E – ROLLS-ROYCE MODEL 250-C20B TURBOSHAFT ENGINE..... | 27 |



| | | |
|-----------|--|-----------|
| 6.2 | MD 500E – ROLLS-ROYCE MODEL 250-C20R/2 TURBOSHAFT ENGINE | 28 |
| 6.3 | ENVIRONMENTAL IMPACT | 29 |
| 6.4 | SAFETY | 30 |
| 6.4.1 | <i>Crashworthiness</i> | 30 |
| 6.5 | HUMAN SYSTEMS INTERFACE | 32 |
| 7. | MAINTENANCE AND SERVICING | 35 |
| 7.1 | MAINTENANCE | 35 |
| 7.2 | SERVICING | 38 |
| 7.3 | HOURLY COST | 40 |
| 8. | PRODUCT SUPPORT..... | 43 |
| 8.1 | TRAINING | 43 |
| 8.1.1 | <i>Pilot Training</i> | 43 |
| 8.1.2 | <i>Transition Flight Training</i> | 43 |
| 8.1.3 | <i>Recurrent Flight Training</i> | 43 |
| 8.1.4 | <i>Maintenance Training</i> | 44 |
| 8.2 | WARRANTY | 44 |
| 8.2.1 | <i>Warranty Claims</i> | 44 |
| 8.3 | SERVICE CENTERS | 45 |
| 8.4 | FIELD SERVICE | 45 |



1. FOREWORD

This document presents basic technical description of the five-place MD Helicopters, Inc. (MDHI) MD 500E helicopter built in Mesa, Arizona, USA. It is designed to provide high-level technical information of the helicopter, advantages / features, and configurations. For more detailed information, an MD 500E Product Specification is available by contacting one of the Sales Team Members listed below.

The MD 500E light turbine helicopter allows easy configuration conversion from a five-place personnel transport to a utility helicopter. With a five-blade main rotor and either a 420-shp Rolls-Royce 250-C20B turbine engine or an optional 450-shp Rolls-Royce 250-C20R/2 turbine engine, the MD 500E is the best performing helicopter in its class.

The MD 500E has a relatively small diameter main rotor system and a short tail with a high horizontal stabilizer with two tip plates to provide vertical, longitudinal, and lateral stability in forward flight. Rotor blades can be folded to allow confined-enclosure storage.

The MD 500E is certified for single pilot operation under visual flight rules / visual meteorological conditions.

MD Helicopter, Inc. Sales and Business Development

SALES

Phone: 480.346.6474

FAX: 480.346.6339

E-Mail: sales@mdhelicopters.com



THIS PAGE INTENTIONALLY LEFT BLANK



2. KEY ADVANTAGES AND FEATURES

The MDHI MD 500E is a single turbine engine, rotary-wing aircraft. It has a cruising speed of 135 knots (249 kph / 155 mph), with a useful internal load at maximum gross weight is 1,483 pounds (673 kg). Hover out of ground effect is 9,500 feet (2,896 m) and hover in ground effect is 11,300 feet (3,444 m). The rate of climb at maximum gross weight is 1,770 feet (9.0 m/sec). The maximum operating altitude is 16,000 feet (4,877 m) with a -40 to +52C (-40 to 126F) operating temperature range. The MD 500E can be equipped with a four-blade tail rotor for quieter performance.

The MD 500E Advantages / Features

| <i>Airframe</i> | |
|---|--|
| <ul style="list-style-type: none"> • Simple system design • Mature, field-proven systems and components • Separate cockpit and cabin • 2+2 or 2+3 seating capability • Speed, agility, and load-capable • Certified to 14 CFR Part 27; VFR • Approved / certified in over 50 countries worldwide • External power receptacle | <ul style="list-style-type: none"> • Integrated landing gear dampers • Fully articulated main rotor blades • Main rotor system removal independent from main rotor transmission • Main rotor transmission removal independent from main rotor system • Proven record of high dependability • High availability |
| <i>Integrated Safety Features</i> | |
| <ul style="list-style-type: none"> • Designed for operator ease • Main rotor static mast / base designed to be fail-safe to 100-percent design load • Three-dimensional truss-type structure with integral roll bar • Energy-absorbing airframe with occupant seat crush boxes for 20g shock resistance • Extended, energy-attenuating landing gear • Dual, crash-resistant elastomeric fuel cells mounted between crash-resistant keel beams and bulkheads below the cabin floor | <ul style="list-style-type: none"> • Empennage mounted tail skid • Shoulder / seat belts attached to primary structure • Engine mounted low and at the rear • Fuel filter automatic bypass if filter becomes restricted • Crew-seat four-point restraints • Passenger seats provided with three-point restraints • Caution / warning annunciators / audible warning tones |
| <i>Supportability Features</i> | |
| <ul style="list-style-type: none"> • Designed for ease of maintenance and supportability | <ul style="list-style-type: none"> • Maximum use of line replaceable units (Contd.): |



The MD 500E Advantages / Features

| | |
|--|---|
| <ul style="list-style-type: none"> • Modular system design • Designed for reparability • Low direct operating costs • Maximum use of line replaceable units: <ul style="list-style-type: none"> ○ Engine ○ Avionics / communication ○ Flight controls ○ Main rotor blades ○ Main rotor drive shaft ○ Main rotor transmission ○ Main rotor transmission drive shaft ○ Main rotor mast ○ Tail rotor gearbox ○ Tail rotor blades ○ Landing gear ○ Canopies ○ Doors ○ Door handles ○ Door windows ○ Seat restraints ○ Tail boom ○ Oil-cooler / blower | <ul style="list-style-type: none"> ○ Empennage ○ Tail boom skid • Built-in Maintenance aids: <ul style="list-style-type: none"> ○ Engine fuel and oil filter impending bypass indicators ○ Engine oil chip detector ○ Tail rotor transmission oil chip detector ○ Main rotor transmission oil chip detectors ○ Integrated engine compressor wash system ○ Engine oil filler cap / dipstick ○ Main rotor transmission filler cap ○ Engine, main rotor transmission, and tail rotor transmission oil level sight gage ○ Footsteps located on each side for upper deck access without ground support equipment ○ Landing gear ground handling wheel quick attach feature |
| <p>Human Systems Integration Features</p> | |
| <ul style="list-style-type: none"> • Unobstructed forward 160-degree vertical and 220-degree horizontal cockpit field of view • Cockpit designed to accommodate 25th to 95th percentile male / female flight crew • Integrated cockpit and cabin entry steps | <ul style="list-style-type: none"> • Tail rotor drive shaft labeled for assembly ease / installation error-proofing • Integrated visual / audible warning indication for flight critical functions |
| <p>Engine</p> | |
| <ul style="list-style-type: none"> • Fuel efficient, field-proven, turboshaft engine | <ul style="list-style-type: none"> • Externally accessible water wash system |
| <p>Monitoring Instrumentation</p> | |
| <ul style="list-style-type: none"> • Caution / warning annunciator panel located at the top of the instrument panel | <ul style="list-style-type: none"> • Digital upgrade pending |
| <p>Environmental Impact</p> | |
| <ul style="list-style-type: none"> • Lower noise profile possible with four-blade tail rotor | |



3. CERTIFICATION

The MDHI MD 500E is a commercial Federal Aviation Administration (FAA) type-certified aircraft under Code of Federal Regulations Title 14, Part 27, Type Certified as the 369E. The MD 500E was initially certified on July 1983. The MD 500E (369E) is also a European Aerospace Safety Administration (EASA) Type Certified helicopter.

Production, type, and supplemental type certificates are maintained by MDHI.

A standard airworthiness certificate (FAA form 8100-2), displayed in the aircraft is the FAA official authorization allowing for the operation of type-certificated aircraft. The airworthiness certificate is displayed in the aircraft and remains valid as long as the aircraft meets the approved type design, is in a condition for safe operation, and maintenance, preventive maintenance, and alterations are performed in accordance with Code of Federal Regulations Title 14, Part 21.



The FAA designation is 369E, and the International Civil Aviation Organization (ICAO) Type Designation is H500. MD Helicopters, Inc. commercial designation is MD 500E.



THIS PAGE INTENTIONALLY LEFT BLANK



4. DIMENSIONS, WEIGHT, AND MISSION CONFIGURATION

4.1 External Dimensions

The MD 500E external dimensions are provided in the following table and shown in the figure below.

MD 500E External Dimensions

| Parameter | Dimension, ft (m) |
|----------------------------------|----------------------|
| Fuselage Width | 4.57 (1.40) |
| Fuselage Length | 23.88 (7.28) |
| Horizontal Stabilizer Width | 5.43 (1.66) |
| Landing Skid Width | 6.45 (1.97) |
| Ground to Rotor Height | 8.65 (2.64) |
| Ground to Fuselage Bottom Height | 1.77 (0.54) |
| Main Rotor Diameter | 26.40 (8.05) |
| Tail Rotor Diameter | 4.58 (1.40) |

4.2 Internal Dimensions

The MD 500E interior dimensions are provided in the following table and shown in the second figure below.

MD 500E Internal Dimensions

| Parameter | Second Figure Reference Location | Dimension, in. (cm) |
|----------------------------------|---|------------------------|
| Crew Compartment Width | A | 49.00 (124.50) |
| Crew Seat to Instrument Panel | B | 18.50 (47.00) |
| Crew Compartment Depth | C | 37.50 (95.30) |
| Passenger Seat to Front Bulkhead | D | 19.00 (48.30) |
| Passenger Compartment Depth | E | 29.00 (73.70) |
| Passenger Compartment Width | F | 44.50 (113.00) |

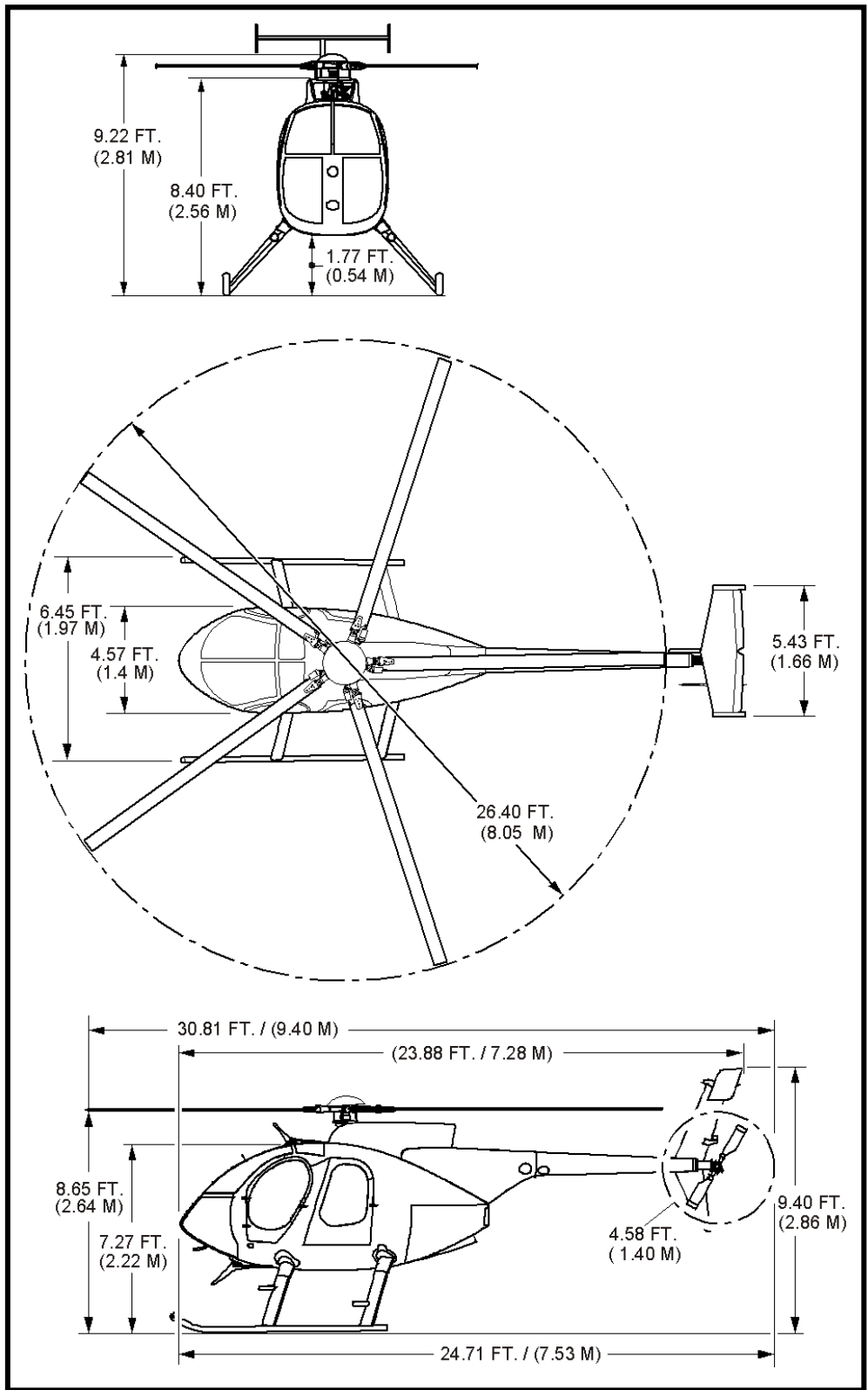

MD 500E External Dimensions

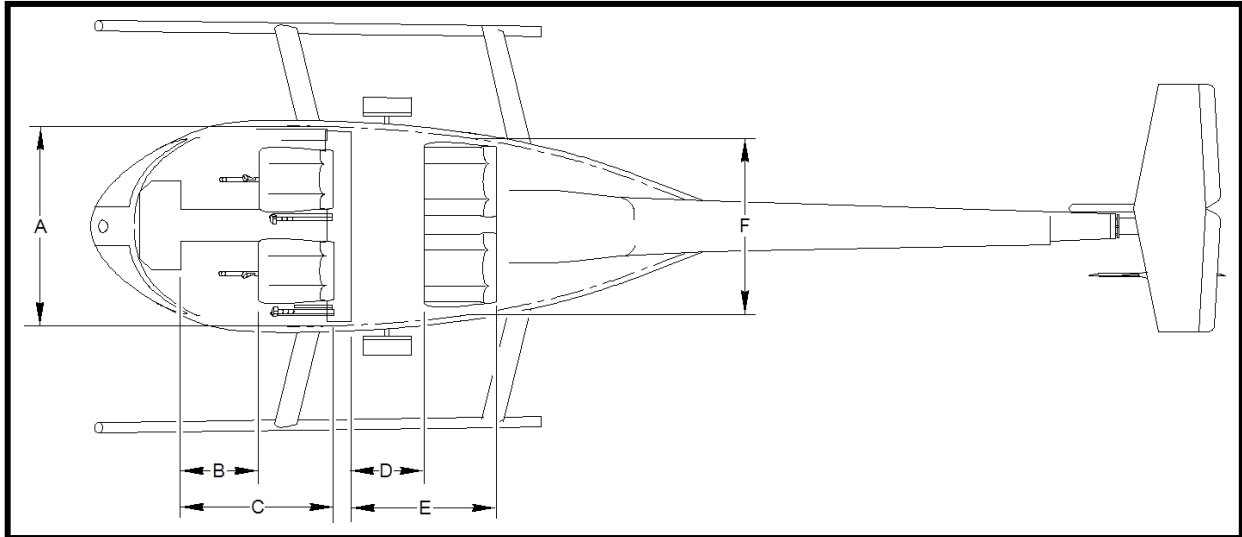

MD 500E Internal Dimension Locations

4.3 Weight

Using the Rolls-Royce Model 250-C20B turboshaft engine, the MD 500E nominal empty weight is 1,481 pounds (672 kg). Using the Rolls-Royce Model 250-C20R/2 turboshaft engine, the MD 500E nominal empty weight is 1,517 pounds (686 kg).

4.4 Configurations

Typical mission applications for the MD 500E helicopter are aerial survey, photography assignments, agricultural, firing fighting, air rescue, police air support, and numerous other missions within the paramilitary, construction, petroleum, and forestry industries.



THIS PAGE INTENTIONALLY LEFT BLANK



5. MD 500E SINGLE-ENGINE HELICOPTER

The MD 500E is a single turbine engine, rotary-wing aircraft originally certified as the Model 369E and built for the U.S. Army. The MD 500E is certified for single pilot operation under visual flight rules / visual meteorological conditions.

5.1 System Description

The MD Helicopters, Inc. MD 500E is a five-place, single-engine, multipurpose helicopter. It has a fully-articulated five-blade main rotor system, and uses a two-blade tail rotor for anti-torque. An optional four-blade tail rotor is available for noise reduction. Power from the turboshaft engine is transmitted through the main drive shaft to the main rotor transmission, and from the main rotor transmission through a drive shaft to the tail rotor. A one-way clutch between the engine and main rotor transmission permits main-rotor freewheeling during auto-rotation. The rotor is supported by a hollow static mast mounted to the primary structure that absorbs all of the flight loads, allowing the transmission to provide only torque.

The fuselage is teardrop-shaped, aerodynamically efficient, and is a semi-monocoque construction, manufactured primarily of aluminum alloy. The airframe includes doors for the pilot, copilot, and passenger area on both sides. Doors can be quickly removed and the helicopter flight-operated without the doors.

The MD 500E, fixed-position, T-tail empennage consists of a horizontal stabilizer with tip plates mounted to the top of a vertical stabilizer. A tail skid is mounted to the bottom of the T-tail empennage. The empennage is mounted at the end of the tail boom on the right-hand side, opposite the tail rotor gearbox, and is constructed of aluminum alloy.

A diagram of the major system components of the MD 500E is shown on the following page.

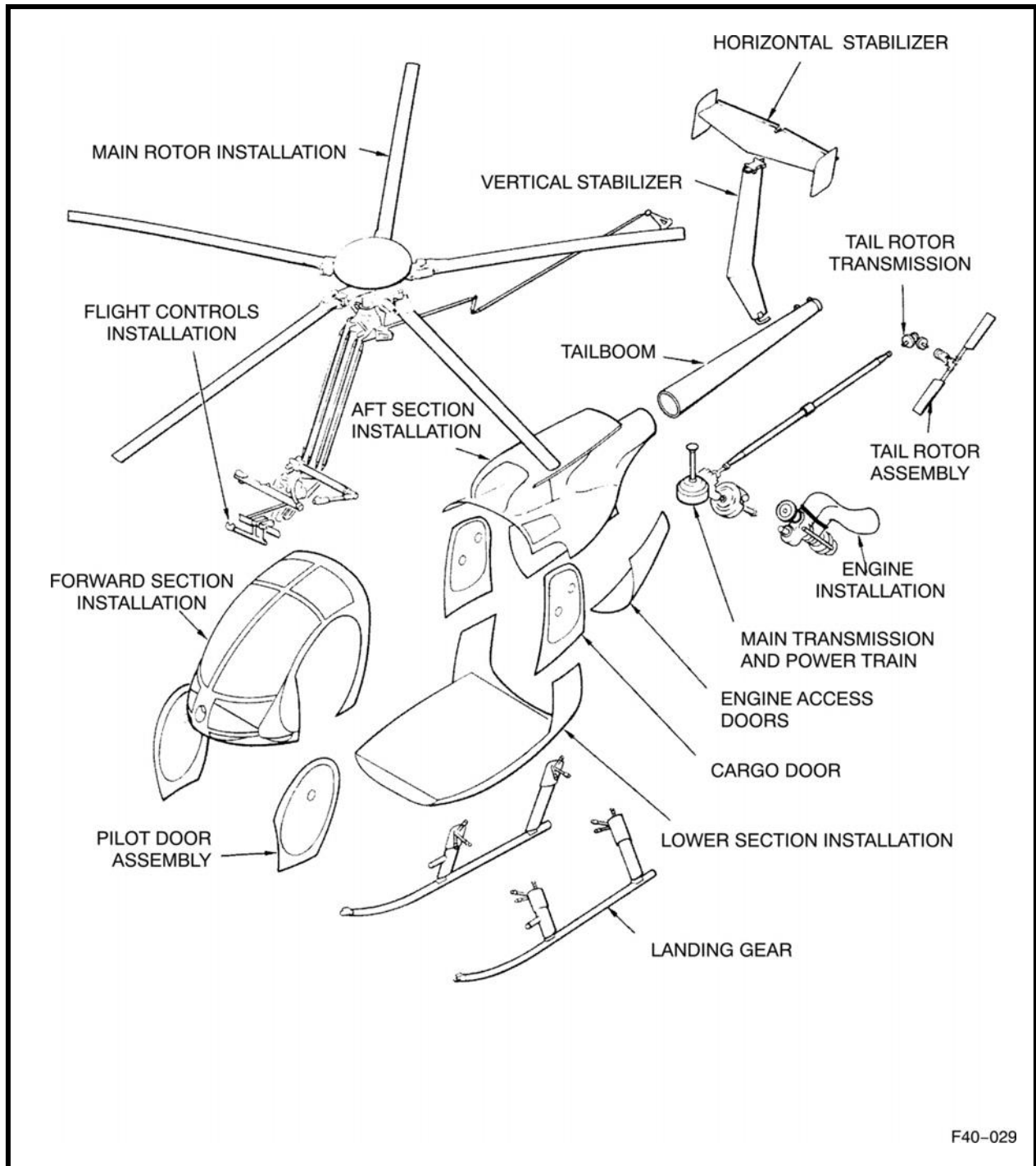

MD 500E Helicopter Major Components



5.2 Standard Equipment

The MD 500E is configured with standard equipment that is included in the basic aircraft procurement.

MD 500E Standard Equipment

| <i>Airframe</i> | |
|---|---|
| <ul style="list-style-type: none"> Extended landing gear Rapid door removal hinges (cockpit and cabin) Tinted canopy windows Tinted door windows Rain gutter set Keyed locks (4) Fuselage hard mounts External power receptacle Jack fitting | <ul style="list-style-type: none"> Carbide skid shoes One-color exterior paint Passenger steps Dual left-hand command flight controls Anti-collision lights (2) Landing light, nose mounted Position lights 85-amp starter-generator 64-gallon (242 liter) fuel system Battery heavy duty 17 amp-hour battery |
| <i>Interior - Cockpit</i> | |
| <ul style="list-style-type: none"> Left hand rotor brake Heater defogger system Crew seats with four-point harness restraint Vinyl and fabric cushions Vinyl interior trim panels | <ul style="list-style-type: none"> Crew compartment floor carpet Map case Fire extinguisher First aid kit Fresh air ventilation system Instrument lighting |
| <i>Interior - Cabin</i> | |
| <ul style="list-style-type: none"> Passenger seats with three-point harness restraint Vinyl and fabric cushions Vinyl interior trim panels Cabin compartment floor carpet | <ul style="list-style-type: none"> Cabin convenience light Cabin soundproofing Cargo tie-down fittings Cabin 28-volt utility outlet |
| <i>Engine</i> | |
| <ul style="list-style-type: none"> Rolls-Royce 250-C20B engine, 420 shp (313 kW) Automatic engine re-ignition Inlet barrier filter | <ul style="list-style-type: none"> Engine anti-ice Engine wash kit Facet oil filter |
| <i>Monitoring Instrumentation</i> | |
| <ul style="list-style-type: none"> Dual tachometer, NR and N2 Engine oil pressure indicator Engine oil temperature indicator Engine torque meter N1 tachometer Fuel quantity indicator | <ul style="list-style-type: none"> Engine chip detector warning light Engine out warning light Fuel filter obstruction warning light Fuel low warning light Generator out warning light Low rotor rpm warning light |



MD 500E Standard Equipment

| | |
|--|---|
| <ul style="list-style-type: none"> • Digital chronometer • Airspeed indicator • Barometric altimeter • DC ammeter • Outside air temperature indicator • Magnetic compass • Turbine outlet temperature indicator • Battery over-temperature warning light | <ul style="list-style-type: none"> • Main transmission chip detector warning light • Main transmission oil pressure warning light • Main transmission oil temperature warning light • Tail rotor transmission chip detector warning light |
| Miscellaneous | |
| <ul style="list-style-type: none"> • Engine, airframe, and battery log books • Rotorcraft flight manual • System/subsystem maintenance manuals and illustrated parts catalogs • Engine exhaust cover | <ul style="list-style-type: none"> • Engine inlet cover • Pitot tube cover • Main rotor blade tie-downs • Ground handling wheels |

5.3 MD 500E Optional Equipment

Optional equipment for the MD 500E is available for additional cost, and is literally non-exhaustive.

MD 500E Optional Equipment

| | |
|---|---|
| Airframe | |
| <ul style="list-style-type: none"> • Heated pitot tube • Paravision door openers • Comfort windows • Dual side mount • Moveable landing/searchlight • Landing light pulse system • Video turret side mount • Pilot Mason Grip • Airframe fuel filter • Generator cooling kit • Engine bay quick release hinges • Exterior crew handles • Air conditioning R-134 w/ forward evaporator • Skid mirror | <ul style="list-style-type: none"> • Sealed lead-acid battery • Cargo hook with hard mount • Cargo hook provisions • On-board cargo hook weighing system • Emergency water floats • Four-blade tail rotor • High-visibility main rotor blades • Two-/three-color standard exterior paint • Night vision goggle compatible lighting • Wire strike protection kit • Twenty-one gallon auxiliary fuel tank • Thirty-three gallon auxiliary fuel tank • Tyler platform • Searchlights |



MD 500E Optional Equipment

| <i>Interior - Cockpit</i> | |
|--|---|
| <ul style="list-style-type: none"> • Leather covered interior panels • Leather covered seats • Black mesh seats • 28-volt receptacle • Pilot/copilot gooseneck lights | <ul style="list-style-type: none"> • Right-hand command pilot • Instrument panel face plate modification • Slant panel pedestal • Night vision goggle compatible lighting |
| <i>Interior - Cabin</i> | |
| <ul style="list-style-type: none"> • Leather covered interior panels • Leather covered seats | <ul style="list-style-type: none"> • Black mesh seats • 28-volt cabin and cockpit receptacles |
| <i>Engine</i> | |
| <ul style="list-style-type: none"> • Rolls-Royce 250-C20R/2 engine, 450 shp (335 kW) | |
| <i>Monitoring Instrumentation</i> | |
| <ul style="list-style-type: none"> • Diamond J turbine outlet temperature indicator • Avionics cooling fan • Blind encoder • Encoding altimeter 3-inch • Instantaneous vertical speed indicator • Radar altimeter w/indicator • Attitude gyro indicator, 3-inch • Directional gyro - panel mounted • Compass system (KCS55A) • Radio magnetic indicator (K1229-00) • Turn and bank indicator, 2-inch • Turn and bank indicator, 3-inch | <ul style="list-style-type: none"> • Various NAV / COM / GPS equipment • Various transponders • Various displays, radios, transceivers, and data links • Various audio panels, intercoms, CD player, AM / FM radios • Cyclic remote frequency switch • Hand held radio provisions to include AA-34 universal • Communication headsets External PA / siren system • Forward looking infrared sensor • Aero Computers mapping system |

5.4 Fuselage

The MD 500E fuselage is a semi-monocoque construction, manufactured primarily of aluminum alloy. It consists of a rigid, three-dimensional truss type structure, with an integral roll-bar design, for increased occupant safety. The airframe structure is designed to be energy absorbing and fails progressively in the event of impact. Occupant seat crush boxes are incorporated into the design and provide 20g shock resistance.

The airframe includes doors for the pilot, copilot, and both sides of the passenger area that can be quickly removed for flight.

The fuselage structure (shown below) is divided into the following three main sections:

- **Forward section** - comprised of a pilot compartment and, directly aft separated by a bulkhead, a passenger / cargo compartment. The pilot compartment is equipped with seats for the pilot and either a copilot, or with copilot controls removed, one or two passengers. The passenger / cargo compartment, located in the aft section of the aircraft, contains provisions for installation of a bench or individual folding-type seats for two to three passengers. The lower fuselage structure beneath the pilot / passenger floor contains compartment space for the aircraft battery and provision for small cargo storage or installation of avionics equipment.
- **Aft section** - includes the structure for the tail boom attachment and engine compartment.
- **Lower section** - divided by the center beam and provides the housing for the two fuel cells. Provisions for the attachment of a cargo hook are located on the bottom of the fuselage in line with the center beam.

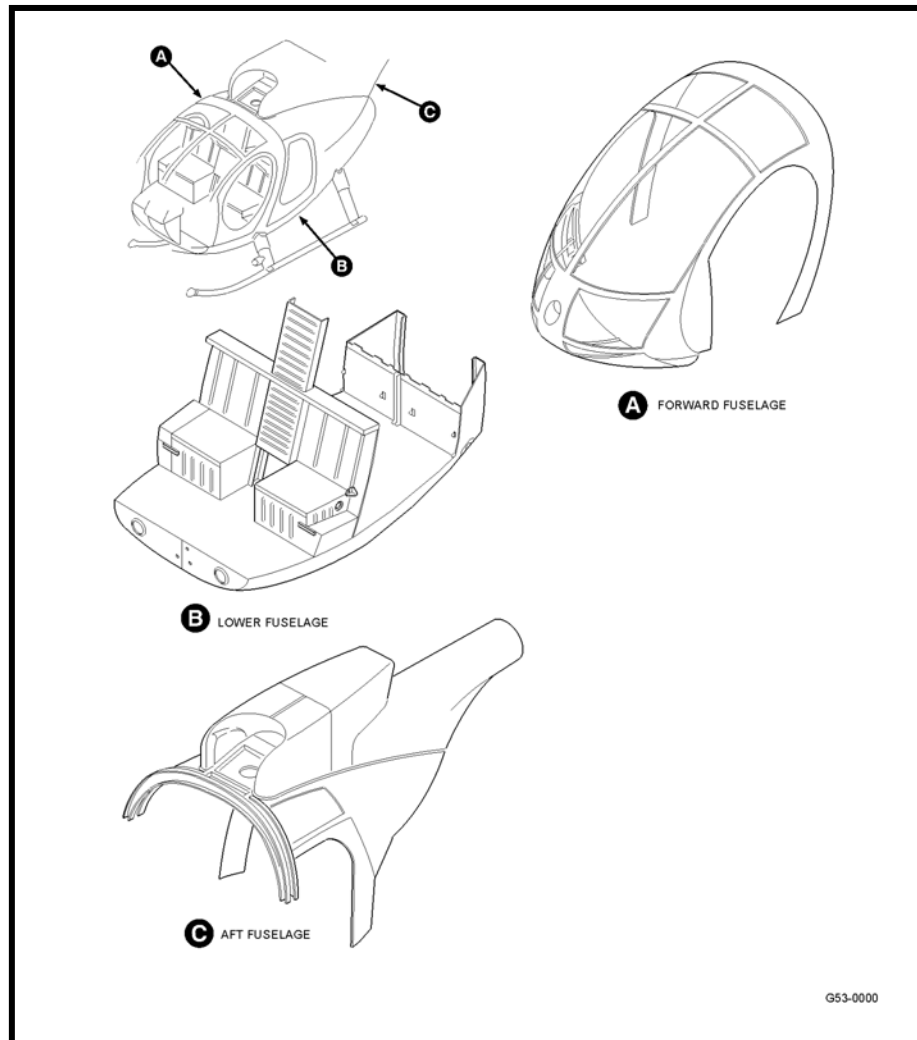

MD 500E Main Fuselage Assembly Sections

5.5 Exterior

The MD 500E exterior can be painted a single color of the customer choice from available colors. Two, three, or more colors can be painted on the exterior for an additional cost. The exterior provides mounting location for external antennas of customer-purchased avionics / communication equipment, external lighting, main rotor static mast, landing gear, and tail boom.

5.6 External Lighting

The MD 500E external lighting (shown below) consists of a:

- Rear position light assembly
- Rear anti-collision strobe light assembly
- Lower anti-collision strobe light assembly
- Left-hand red position light assembly
- Right-hand green position light assembly
- Landing hover light.

Standard cockpit lighting includes a cockpit light for the pilot. A passenger compartment convenience light is optional.

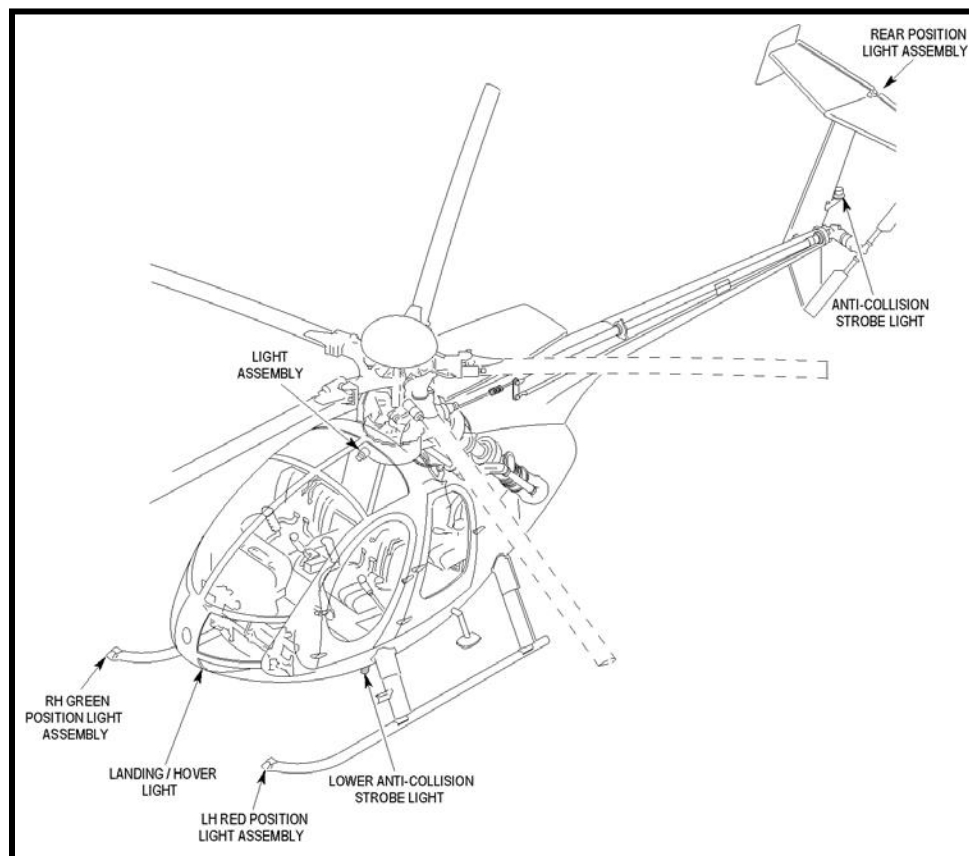

MD 500E Internal and External Lighting Locations

5.7 Interior

The MD 500E interior consists of the cockpit area, cabin compartment area, and engine compartment. The MD 500E is provided with the utility interior.

5.7.1 Cockpit

The cockpit has accommodations for the pilot and / or copilot. The minimum crew is one pilot in the command position. The T-shaped instrument panel is located in the forward portion of the cockpit, and provides space for a full complement of avionics equipment. The instrument panel layout allows for easy scanning of flight instruments.



The cockpit is ergonomically designed to facilitate single pilot operation in the left-hand or right-hand command configuration. All controls are within easy pilot reach. In addition, the anti-torque tail rotor control pedals are adjustable for up to 4 inches fore and aft to accommodate 25th-percentile to 95th-percentile male / female pilots. Seats are constructed of padded upholstered material and are attached to the forward bulkhead. Directly aft of the crew station, a bulkhead behind the forward compartment separates the cockpit and passenger / cargo compartment.

5.7.2 Cabin Compartment

The passenger / cargo compartment provides space for passengers, cargo, or multi-mission equipment. The rear portion of the passenger / cargo compartment provides increased headroom and visibility. Standard seats are constructed of padded upholstered material and are attached to the rear bulkhead. Optional aluminum tube frame and black mesh seats are also available.



5.7.3 Engine Compartment

The engine compartment is located aft and below the passenger / cargo compartment. The engine compartment provides an enclosed mounting platform for the turboshaft engine and can be easily accessed behind two clam-shell type doors contoured to the shape of the fuselage. The engine compartment can be easily accessed without ground support equipment or special equipment.

5.8 Systems

5.8.1 Fuel System

The MD 500E fuel system consists of two interconnected bladder cells with a total capacity of 64 gallons (242.30 liters) located in bays below the passenger / cargo compartment floor of the lower section. Each bladder cell is internally supported by the airframe and contains electrically-powered fuel quantity transmitters that monitor fuel level and provide fuel quantity to the pilot. Low fuel level is displayed to the pilot through a yellow caution light on the instrument panel. Fuel flow from the bladder cells can be manually shutoff by the pilot using a mechanically actuated fuel shutoff valve control located on the instrument panel.

5.8.2 Propulsion System

The engine used in the MD 500E is the Rolls-Royce Model 250-C20B gas turbine engine that produces 420 shp, derated to 375 shp for takeoff, and 350 shp at maximum continuous operation. As an option, a Rolls-Royce Model 250-C20R/2 turboshaft engine that produces 450 shp, derated to 375 shp for takeoff, and 350 shp at maximum continuous is available. Both engines consist of a combined four-stage axial and single-stage centrifugal compressor, a can-type combustion chamber, a four-stage turbine assembly, exhaust pipe, and accessory gearbox (AGB).

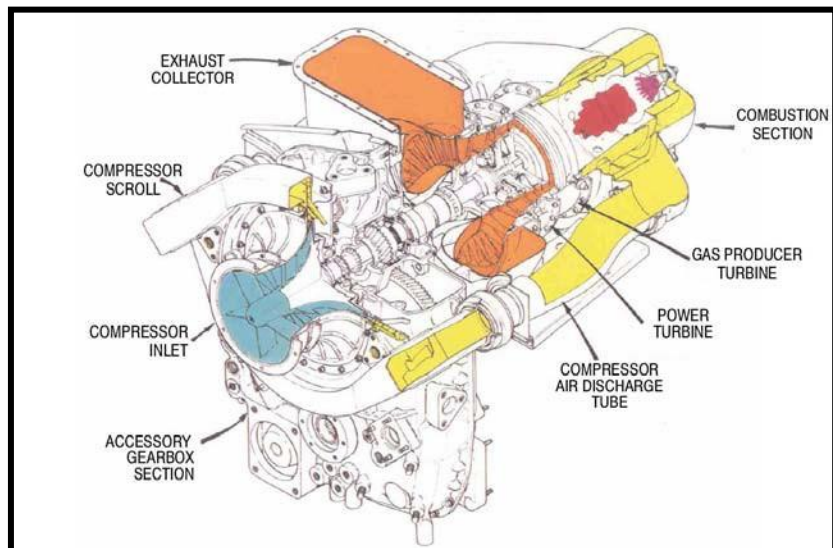

Typical Rolls-Royce Model 250 Turboshaft Engine Cross Section

The Model 250-C20B and 250-C20R/2 engines have an automatic re-ignition system that provides automatic activation (and pilot indication) of the ignition exciter activation in the event of an engine flameout and resulting engine power loss.

5.8.2.1 Engine Controls

Engine control is accomplished by fuel control actuation using the throttle twist grip located at the end of the collective stick. The throttle twist grip has three positions: cutoff, idle, and full open. Moving the throttle twist grip from cutoff to idle provides automatic fuel metering for engine starting, acceleration, and idle stabilization. Moving the throttle twist grip to full open during operation increases the gas producer speed and allows the power turbine governor speed



control. The collective stick throttle twist grip movement friction is adjustable, and can also be locked when the operational gas producer turbine speed is attained.

5.8.3 Drive System

The MD 500E drive system, shown in the figures below, consists of:

- Main rotor static mast – Non-rotating and is rigidly mounted to the mast support structure. It provides support for the main rotor, main rotor transmission, and main rotor transmission drive shaft
- Main rotor drive shaft – Transmits torque to the main rotor. Lifting loads are prevented from being imposed on the main transmission, eliminating thrust loading of transmission parts
- Main rotor transmission – Mounted to the basic airframe structure above the passenger / cargo compartment, the main rotor transmission is lubricated by a self-contained air-cooled lubrication system
- Overrunning clutch – The overrunning clutch transmits power from the engine to the main rotor transmission drive shaft
- Main rotor transmission drive shaft – Connects to the main rotor transmission input shaft
- Oil Cooler – The oil cooler is a two section cooler with an upper and lower part. The upper part is used to cool the transmission lubricating oil and the lower part is used to cool the engine lubricating oil
- Oil-cooler / blower – Belt driven off the main drive shaft, it draws cooling air from the air inlet fairing to supply ambient air to the engine and transmission oil coolers and to the engine compartment
- Tail rotor drive shaft – Connects the main rotor transmission and tail rotor transmission. Incorporated tail rotor drive shaft dampers reduce vibration in the tail rotor drive system
- Tail rotor transmission – Mounted on the aft end of the tail boom and has a self-contained lubrication system. The tail rotor is mounted on the output shaft of the tail rotor transmission and consists of two variable-pitch blades.

5.8.4 Rotor System

The static mast-hub support system, unique to MDHI products, uses a static mast, rigidly attached to the fuselage. All dynamic loads are transmitted through the mast, rather than through the transmission. A separate, inner drive shaft transmits engine torque to the main rotor hub. This feature offers improved flight control integrity and helps retain rotor system components in the event of a main rotor blade strike. Additionally, this approach allows for the design of a main transmission that is lighter in weight, and can be removed without disturbing the hub or control system.

The MD 500E utilizes a five-blade, fully articulated main rotor assembly. Rotor blades, pitch housings, and links are secured to the hub by laminated steel strap sets. These sets are used in lieu of typical thrust bearing stacks to contain blade centrifugal loading and allow feathering.

The strap sets provide additional functionality:

- The strap set configuration (which is secured firmly to the hub) allows the centrifugal load exerted by one blade to be countered by the force exerted by the opposite two blades, resulting in very light centrifugal loads exerted on the hub.
- The V-legs of the strap set rotate as driving members to turn the main rotor blades.
- The strap sets are configured to allow feathering and flapping of the blades.

Main rotor blades are retained to the main rotor hub using captive cam-handle-type blade retention bolts.

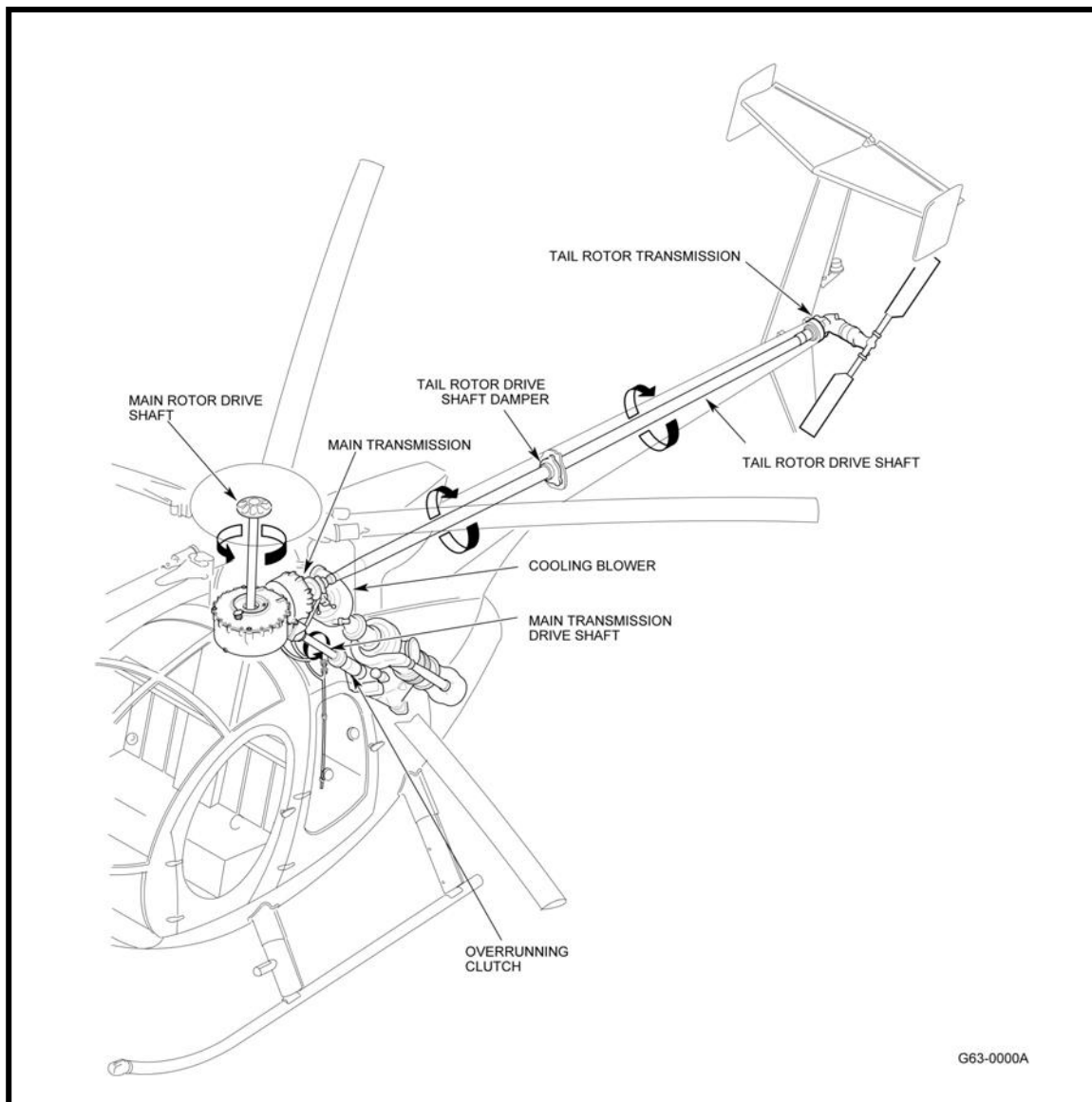

MD 500E In-Situ Drive System

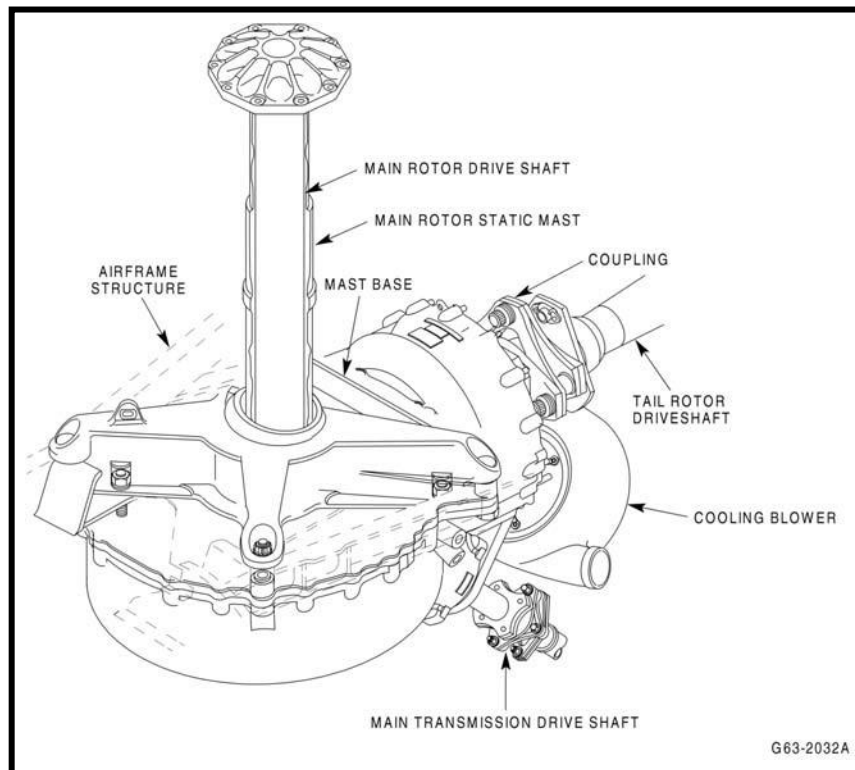

MD 500E Main Transmission Drive System

5.8.5 Inlet Barrier Filter System

Structural fairings are integrated into the existing MD 500E cowling (see figure below) to allow dual-entry engine airflow distribution through the two filters in hover or forward flight. The inlet barrier filter system, shown on the following page, provides up to 99-percent dust, sand, and dirt separation protection. The filter elements can be easily removed and replaced without special tools.

5.8.6 Flight Control System

The flight control system consists of a conventional helicopter control system for collective, cyclic, and anti-torque tail rotor control. The cyclic and collective control sticks incorporate friction devices as a method for the pilot to vary movement friction and the amount of effort required to move the control sticks. The cyclic stick lateral and longitudinal movement friction is adjustable. The collective stick vertical movement friction and the throttle twist grip movement friction are adjustable. The collective stick throttle twist grip can also be locked when the operational gas producer turbine speed is attained. The copilot flight controls can be easily removed to provide room for passengers or cargo.

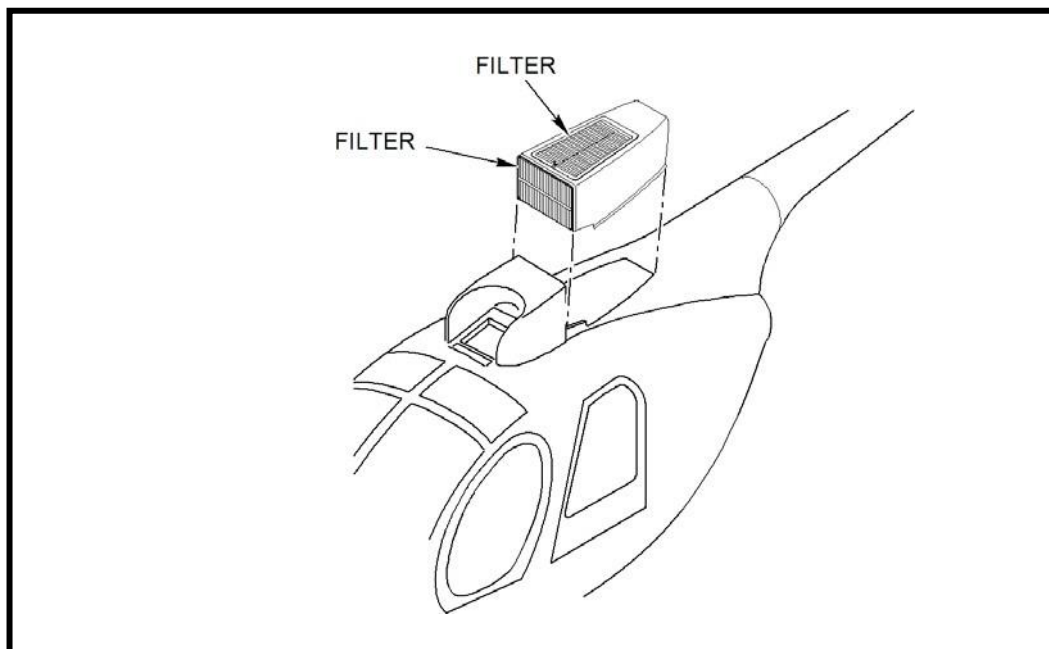

Inlet Barrier Filter System Consists of Two Air Filters

5.8.7 Electrical System

The MD 500E electrical system is a direct current (dc) system with electrical power supplied by a 24-volt nickel-cadmium battery and a 28-volt, 85-amp engine-driven generator. The electrical system incorporates a generic electrical wire harness that is shielded to minimize electro-magnetic interference (EMI). Forward and aft line relay contacts protect main power bus and feeder wires. Over-voltage diodes protect circuits from excessive ground power voltages. An external power receptacle is available for ground power.

5.8.8 Environmental Control System

Cabin environmental control is accomplished by an integral heating and defogging system and an external-air circulation system. The heating and defogging system requires no additional equipment and uses oil cooler blower supplied unheated air and turboshaft engine compressor supplied heated air.

Cabin ventilation with ambient external air is available using instrument panel mounted mechanical controls to operate a moveable vane. In addition, adjustable window-mounted ventilators are installed in each door window to provide in-flight, outside forced air into the cabin or provide vent-air exhaust.

An air conditioning system is an available option.



5.8.9 Monitoring Instrumentation

Typical MD 500E monitoring instrumentation provided as standard equipment includes:

- Dual engine tachometer (NR and N2)
- Engine oil pressure
- Engine oil temperature
- Engine torque meter
- Engine N1 Tachometer
- Engine turbine outlet temperature
- Fuel quantity
- Airspeed
- Barometric altimeter
- Magnetic compass
- Outside air temperature
- Direct current ammeter
- Fuel quantity
- Digital chronometer
- Annunciator panel caution / warning lights
 - Engine chip detector light
 - Engine-out warning
 - Fuel filter warning
 - Fuel low warning
 - Generator-out warning
 - Battery over-temperature warning
 - Low-rotor revolutions per minute (rpm) warning
 - Main rotor transmission chip detector warning
 - Main rotor transmission oil pressure warning
 - Main rotor transmission oil temperature warning
 - Tail rotor transmission chip detector warning.

5.8.10 Caution / Warning Annunciators

Caution and warning annunciators (indicators) are located at the top of the instrument panel above the flight instruments. A caution indication will be indicated by a yellow indicator illumination. A warning indication will be indicated by a red indicator illumination.

Additionally, an audible warning tone will be presented for an engine out and low rotor speed indication with the corresponding warning indicator illumination.

5.8.11 Avionics / Communications

The MD 500E is provided with a standard avionics suite. Optional purchaser configured avionics, communications, instrumentation, etc., may be added at additional expense. To accommodate additional avionics / communication equipment, an optional slant console panel installation is available.



5.8.11.1 Next-Generation Electronic Flight Instrument System

The MD 500-series helicopters will incorporate a modernized instrumentation / avionics cockpit consisting of a Garmin G500 suite that includes a multi-function and primary flight displays (MFD, PFD) and an engine indicating and crew alerting system (EICAS). The EICAS will replace the caution and warning annunciators. The next-generation electronic flight instrumentation system will work with additional equipment such as a GTN650 GPS / NAV / COM and automatic dependent surveillance-broadcast (ADS-B) to provide next-generation air transportation system compatibility.



THIS PAGE INTENTIONALLY LEFT BLANK



6. PERFORMANCE SPECIFICATIONS

Performance specifications for the MD 500E helicopter with the standard Rolls-Royce Model 250-C20B turboshaft engine and the optional Rolls-Royce Model 250-C20R/2 turboshaft engine are provided below.

6.1 MD 500E – Rolls-Royce Model 250-C20B Turboshaft Engine

Using the Rolls-Royce Model 250-C20B turboshaft engine, the MD 500E has a nominal empty weight of 1,481 pounds (672 kg), and a maximum gross takeoff weight of 3,000 pounds. Ratings are for the MD 500E with a Rolls-Royce 250-C20B Model turboshaft engine rated at 420 shp (313 kW), derated to takeoff power – 375 shp (280 kW), maximum continuous power – 350 shp (261 kW).

MD 500E Performance Specifications (Rolls-Royce Model 250-C20B)

| Parameter | Condition | Imperial | Metric |
|--|------------------------------|-----------|---------|
| Maximum Cruise Speed, kt (mph) [km/hr] | Sea Level ISA | 135 (155) | [249] |
| | 5000 ft, ISA | 120 (138) | [222] |
| Maximum Permitted Speed, kt (mph) [km/hr] | V _{NE} at Sea Level | 152 (175) | [282] |
| Maximum Range, nm (mi) [km] | Sea Level, ISA | 258 (297) | [478] |
| | 5000 ft, ISA | 290 (304) | [537] |
| Maximum Endurance, hr | Sea Level, ISA | 2.8 | 2.8 |
| Maximum Rate-of-Climb (TOP), ft/min (m/sec) | Sea Level Standard Day | 1,770 | (9.0) |
| | ISA +20C Day | 1,776 | (9.0) |
| Maximum Operating Altitude, ft (m) | Density Altitude | 16,000 | (4,877) |
| Service Ceiling, ft (m) | ISA | 13,900 | (4,237) |
| Maximum Hook Capacity, lb (kg) | | 2,000 | (907) |
| Hover-in-Ground Effect (HIGE), ft (m) | Standard Day | 8,500 | (2,591) |
| | ISA +20C Day | 6,000 | (1,829) |
| Hover-Out-of-Ground Effect (HOGE), ft (m) | Standard Day | 6,800 | (2,073) |
| | ISA +20C Day | 3,100 | (945) |
| Maximum Takeoff Gross Weight, lb (kg) | Normal Category | 3,000 | (1,361) |
| MTOGW External Load Operations, lb (kg) | | 3,550 | (1,610) |
| Empty Weight, lb (kg) | Standard Configuration | 1,481 | (672) |
| Useful Load, lb (kg) | Normal Category | 1,519 | (689) |
| External Load Operations, lb (kg) | | 2,069 | (938) |
| Fuel Capacity, lb (kg) | Usable | 403 | (183) |



6.2 MD 500E – Rolls-Royce Model 250-C20R/2 Turboshaft Engine

Using the Rolls-Royce Model 250-C20R/2 turboshaft engine, the MD 500E has a nominal empty weight of 1,517 pounds (686 kg), and maximum gross takeoff weight is 3,000 pounds. Ratings are for the MD 500E with a Rolls-Royce Model 250-C20R/2 turboshaft engine rated at 450 shp (336 kW), derated to takeoff power – 375 shp (280 kW), maximum continuous power – 350 shp (261 kW).

MD 500E Performance Specifications (Rolls-Royce Model 250-C20R/2)

| Parameter | Condition | Imperial | Metric |
|---|------------------------------|-----------|---------|
| Maximum Cruise Speed, kt (mph) [km/hr] | Sea Level, ISA | 135 (155) | [249] |
| | 5000 ft, ISA | 120 (138) | [222] |
| Maximum Permitted Speed, kt (mph) [km/hr] | V _{NE} at Sea Level | 152 (175) | [282] |
| Maximum Range, nm (mi) [km] | Sea Level, ISA | 255 (297) | [472] |
| | 5000 ft, ISA | 287 (330) | [531] |
| Maximum Endurance, hr | Sea Level, ISA | 2.7 | 2.7 |
| Maximum Rate-of-Climb (TOP), ft/min (m/sec) | Sea Level Standard Day | 1,770 | (9.0) |
| | ISA +20C Day | 1,776 | (9.0) |
| Maximum Operating Altitude, ft (m) | Density Altitude | 16,000 | (4,877) |
| Service Ceiling, ft (m) | ISA | 16,500 | (5,029) |
| Maximum Hook Capacity, lb (kg) | | 2,000 | (907) |
| Hover-in-Ground Effect (HIGE), ft (m) | Standard Day | 11,300 | (3,444) |
| | ISA +20C Day | 6,900 | (2,103) |
| Hover-Out-of-Ground Effect (HOGE), ft (m) | Standard Day | 9,500 | (2,896) |
| | ISA +20C Day | 4,100 | (1,250) |
| Maximum Takeoff Gross Weight, lb (kg) | Normal Category | 3,000 | (1,361) |
| MTOGW External Load Operations, lb (kg) | | 3,550 | (1,610) |
| Empty Weight, lb (kg) | Standard Configuration | 1,517 | (686) |
| Useful Load, lb (kg) | Normal Category | 1,483 | (673) |
| External Load Operations, lb (kg) | | 2,033 | (922) |
| Fuel Capacity, lb (kg) | Usable | 403 | (183) |



6.3 Environmental Impact

The MD 500E noise signature is below the FAA and International Civil Aviation Organization (ICAO) noise requirements. The following table provides the decibel values at three MD 500E flight profiles. The figure below provides a noise level comparison (effective perceived noise level [EPNL], in decibels [dB]) for three helicopter models and the ICAO limit.

MD 500E Operational Noise Levels for Three Flight Profiles

| Flight Profile | Measured Value, EPNdB | ICAO Limit | Compliance Margin |
|--------------------|-----------------------|------------|-------------------|
| Takeoff | 86.2 | 91.4 | 5.2 |
| Level Flyover | 84.4 | 90.4 | 6.0 |
| Approach / Landing | 88.4 | 92.4 | 4.0 |

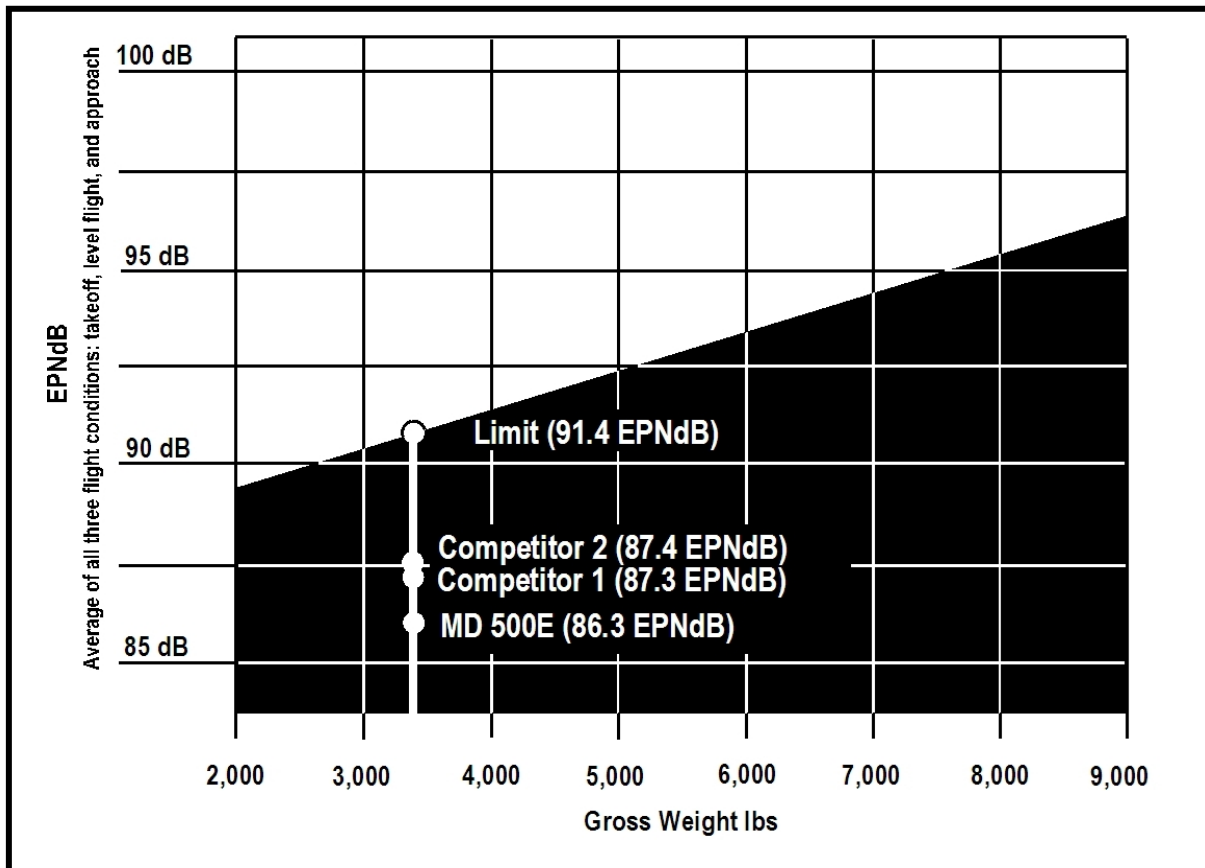

MD 500E Average Noise Certification Level Comparison



The full-page figure below provides a comparison of 500-foot overflight effective, perceived noise levels (EPNLs) of competitor twin-engine aircraft using European Aviation Safety Agency (EASA) data. This figure shows the MD 500E with four-blade tail rotor, MD 520N, and MD 600N helicopters provide the lowest EPNLs of light single-engine helicopters.

6.4 Safety

The MD 500E has inherent safety features. It incorporates a rigid, three-dimensional truss type structure, with an integral roll-bar design for increased occupant safety. The airframe structure is designed to be energy absorbing and fails progressively in the event of impact. The fuel cells are separated well away from the outer skin, enclosed by two deep keel beams. Shoulder and seat belts are attached to the aircraft structure rather than to the seat. The pilot and cabin doors function both as primary and emergency exits.

Occupant seat crush boxes are incorporated into the design and provide 20g shock resistance. The seat crush boxes were originally designed to meet Civil Aviation Regulation, Part 6 (CAR6) requirements and have been validated under Title 14 Code of Federal Regulation (CFR), Chapter 1, Part 27, Subpart C, Section 27.562 for the MD 600N air vehicle. Seat crush boxes for the MD 600N are the same as used in the MD 500-series.

6.4.1 Crashworthiness

The MD 500E is a derivative of the OH-6A observation helicopter used extensively by the United States Army during the Vietnam conflict in which nearly 1500 OH-6A aircraft were operated. The OH-6A earned a reputation for being the most survivable helicopter in the world, due to inherent design features shown in the figure below.

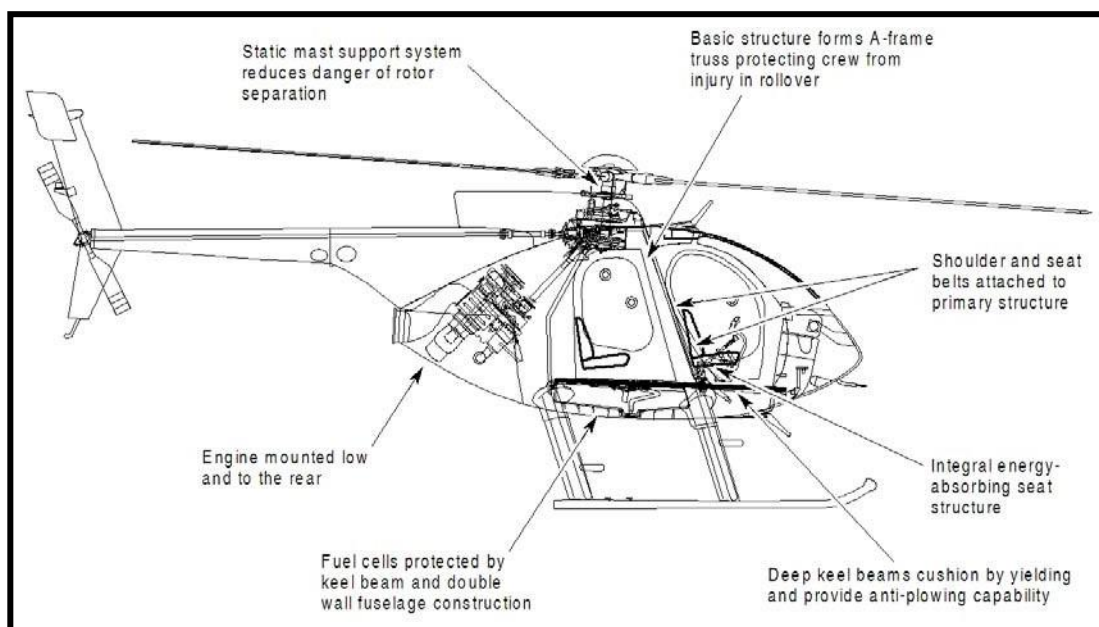

MD 500E-Series Crashworthy Design Features

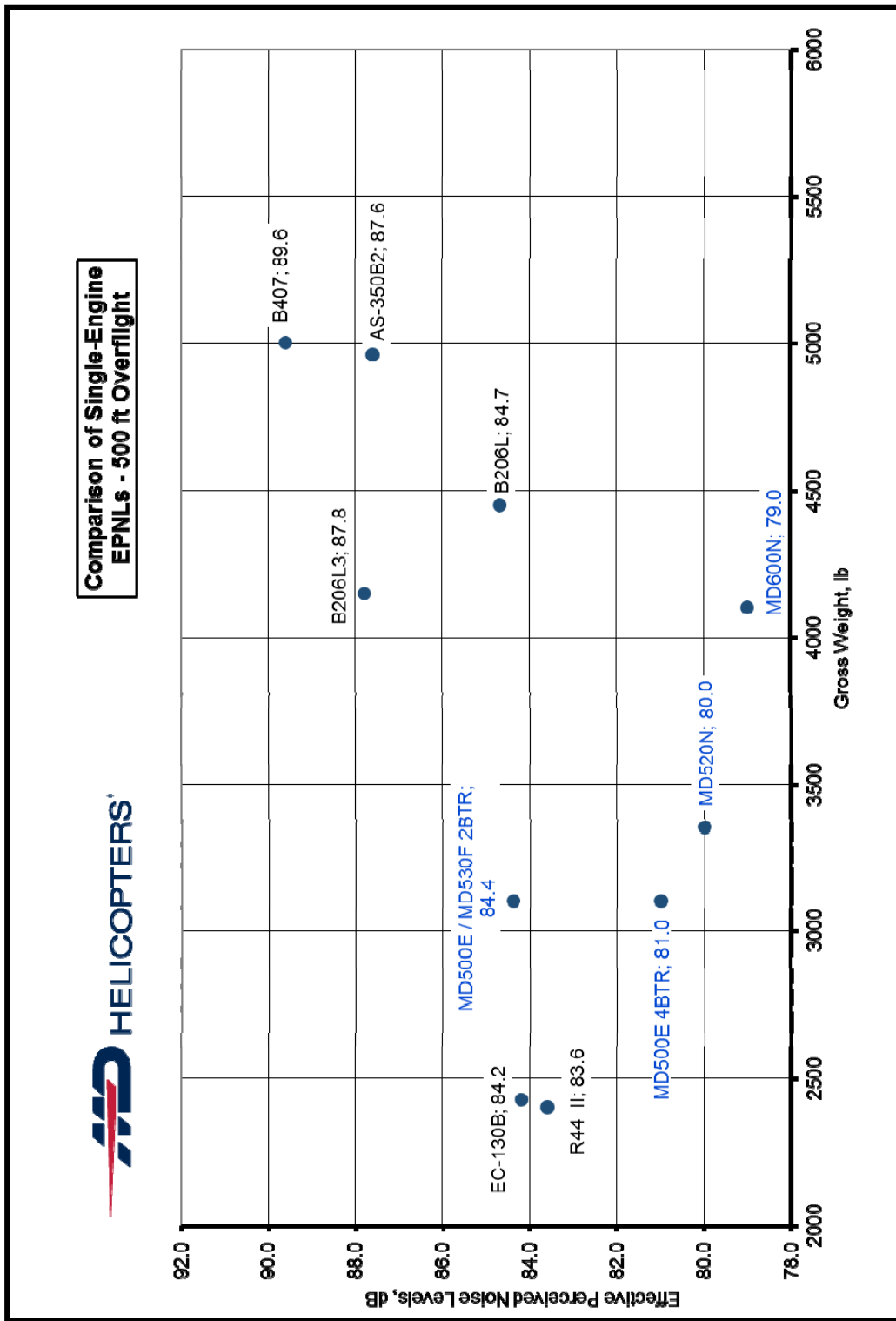

The MD 500E Helicopter has Low 500-Foot Overflight Effective Perceived Noise Levels of Comparable Light Single-Engine Helicopters



Tests on the landing gear and fuselage sections verified the crashworthiness capability of the MD 500-series. The testing indicates that the MD 500-series helicopters will provide occupant protection for approximately 95-percent of all civil accidents, and that the landing gear and airframe fuselage is capable of absorbing vertical descents up to 26.3 feet per second with only moderate crewmember injury.

6.5 Human Systems Interface

The MD 500E incorporates anthropometric design features that are compatible with 25th to 95th percentile male or female crewmembers. Sizing parameters for the 25th and 95th percentile male and female are provided in the table below. The canopy design meets human engineering design requirements for windows, canopies, and windshields, as shown in the figures following the table.

Anthropometric Sizing Parameters

| Parameter | 25th Percentile Female | 95th Percentile Female | 25th Percentile Male | 95th Percentile Male |
|---|--|--|--|--|
| Weight, lb (kg) | 119.3 (54.1) | 164.5 (74.6) | 142.6 (64.7) | 201.8 (91.5) |
| Height, in. (cm) | 62.4 (158.5) | 68.5 (174.0) | 67.0 (170.1) | 73.9 (187.7) |
| Elbow – Hand Grip Reach, in. (cm) | 12.5 (31.7) | 14.1 (35.8) | 13.7 (34.8) | 15.4 (39.1) |
| Thumb Tip Reach, in. (cm) | 27.9 (70.8) | 31.4 (79.7) | 30.4 (77.2) | 34.2 (86.9) |
| Functional Leg Reach Length, in. (cm) | 39.2 (99.6) | 43.2 (109.7) | 43.5 (110.6) | 46.0 (116.8) |

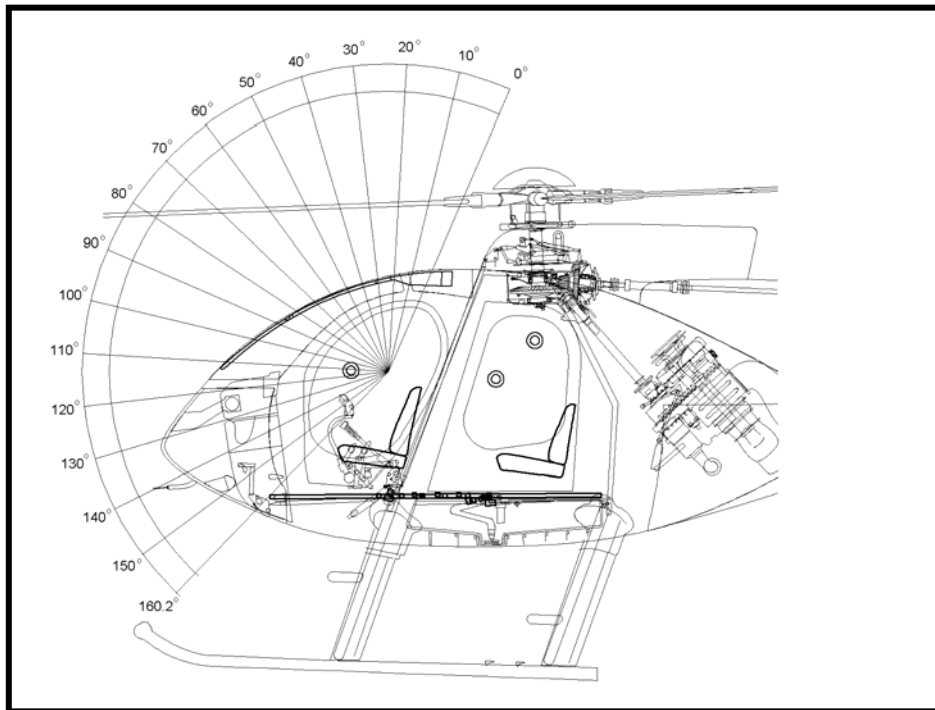

The MD 500E Provides a 160-Degree Vertical Unobstructed View for the Pilot and Copilot

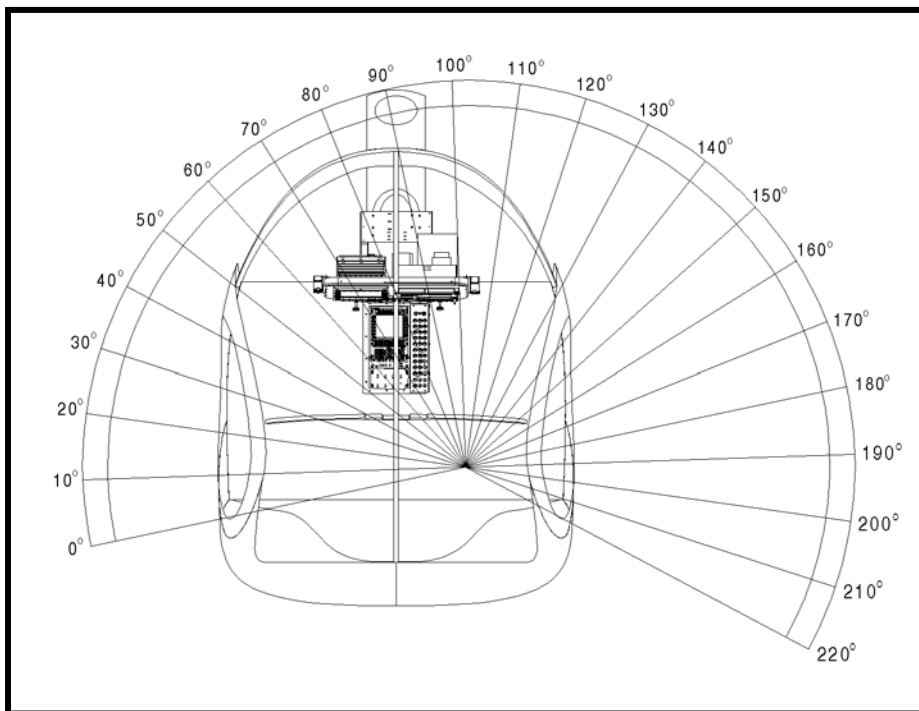

The MD 500E Provides a 220-Degree Horizontal Unobstructed View for the Pilot and Copilot (View is Top-Down)



THIS PAGE INTENTIONALLY LEFT BLANK



7. MAINTENANCE AND SERVICING

The MD 500-series of helicopters were designed for ease of supportability and low-cost operation. Helicopter systems and components are easily accessed and can be maintained at the lowest maintenance level. The helicopter was designed for a high level of, and ease of replacement of line replaceable units (LRUs). The helicopter can be maintained at the line- / shop-maintenance level using common hand tools, with easy to understand technical publications. The MD 500-series helicopter spare parts are readily available, and most parts have corresponding United States Department of Defense National Stock Numbers (NSNs).

7.1 Maintenance

The MD 500E design provides for the maximum maintenance support at the lowest maintenance level. The MD 500E can be maintained using a combination of line and shop maintenance support. Components such as engine, avionics, interior components, air-conditioning, etc., are considered LRUs. Line replaceable units (and any subcomponent shop replaceable units) can be removed and replaced easily and modularly, as necessary, and at the lowest maintenance level allowed.

Typical for small- to mid-sized helicopter systems are fixed time between overhaul (TBO) intervals for the engine, transmission, main rotor, and flight controls. Within these items are also life-limited components that must be monitored and replaced at the end of life hours. When required, components requiring further maintenance action can be removed and forwarded to the appropriate-level shop.

The MD 500E helicopter airframe uses an on-condition maintenance concept, which allows scheduled inspections / checks. To be compliant with commercial regulatory requirements, an MD 500E continued airworthiness inspection program was developed by MDHI. This program provides for schedule inspections, and also includes life-limited component replacement. The maintenance and inspection intervals are provided in the Handbook of Maintenance Instruction. Airframe-related inspection intervals occur every:

- 100 hours
- 300 hours
- 600 hours
- 1200 hours
- Yearly
- Special time-phase inspections.

The engine also has life-limited components, a fixed TBO, and inspection intervals. The MD 500E life-limited parts, overhaul intervals, and inspection intervals are listed in the table below.



MD 500E Life-Limited Parts, Overhaul, and Inspection Intervals

| Component | Life Limit, hr | Overhaul Interval, hr | Inspection Interval, hr |
|---|----------------|-----------------------|---------------------------|
| MAIN ROTOR | | | |
| Blade | 3,530 | | 100 |
| Blade Pin | 7,600 | | |
| Hub Assembly | 8,900 | | 300 |
| Upper Thrust Bearing Cup | | | 2 yr / 2,770 ^① |
| Upper Thrust Bearing Cone | | | 2 yr / 2,770 ^① |
| Lower Thrust Bearing Cup | | | 2 yr / 2,770 ^① |
| Lower Thrust Bearing Cone | | | 2 yr / 2,770 ^① |
| Pitch Housing | 9,100 | | |
| Retention Strap | 2,770 | | 100 |
| Lead-Lag Hub Bolt | 6,120 | | |
| Lead-Lag Hub Link Assembly | 11,080 | | |
| Lead-Lag Dampers | | | 600 ^② |
| Swashplate | | | 2 yr / 2,770 ^① |
| Drive Shaft | 5,020 | | 300 |
| Mast Assembly | 10,450 | | |
| DRIVE SHAFTS, COUPLINGS, AND CLUTCHES | | | |
| Main Rotor Transmission Drive Shaft | 3,790 | | 300 |
| Main Rotor Transmission Drive Shaft Coupling | 4,300 | | |
| Main Rotor Transmission | | 5,000 | |
| Overrunning Clutch Assembly | | 1,800 ^③ | 100/300 ^③ |
| Oil-Cooler / Blower Bearing | | 1,200 | |
| Oil-Cooler / Blower Belt | | 1,200 | |
| ANTI-TORQUE SYSTEM | | | |
| Tail Rotor Drive Shaft | 13,900 | | |
| Tail Rotor Transmission Input Gearshaft | 12,000 | | |
| Tail Rotor Transmission Output Pinion Gearshaft | 7,290 | | |
| Tail Rotor Transmission | | 4,800 | |
| Tail Rotor Blade Assembly | 5,140 | | |
| Tail Rotor Hub | 3,450 | | |
| Tail Rotor Retention Strap Assembly | 5,100 | | |
| TAIL BOOM | | | |
| Tail Boom Attach Bolts | 21,950 | | |
| Tail Boom Assembly | 10,300 | | 100 |
| Vertical Stabilizer Assembly | 12,700 | | 100 |



MD 500E Life-Limited Parts, Overhaul, and Inspection Intervals

| Component | Life Limit, hr | Overhaul Interval, hr | Inspection Interval, hr |
|---------------------------------------|----------------|-----------------------|-------------------------|
| Horizontal Stabilizer Assembly | 7,700 | | 100 |
| CONTROLS | | | |
| Longitudinal Idler Bellcrank Assembly | 6,500 | | 100 |
| Cyclic Stick Trim Switch | 1,000 | | |
| AIRFRAME | | | |
| Battery Over-Temperature Sensor | | | 1200 |
| Interior | | | 100/300 |
| Exterior | | | 100/300 |
| Landing Gear | | | 100/300 |
| Main Rotor | | | 100/300 |
| Drive Train | | | 100/300 |
| Flight Controls | | | 100/300 |
| Anti-Torque System | | | 100/300 |
| Electrical System | | | 100/300 |
| Engine Compartment | | | 100/300 |
| ENGINE④ | | | |
| Compressor Module | | 3,500 | |
| Compressor Impeller | 3,550/9,150⑥ | | |
| Turbine Module | | 3,500 | 1,750⑦ |
| First-Stage Turbine Wheel | 1,775/3,000⑥ | | |
| Second-Stage Turbine Wheel | 1,775/3,000⑥ | | |
| Third-Stage Turbine Wheel | 4,550/6,000⑥ | | |
| Fourth-Stage Turbine Wheel | 4,550/6,000⑥ | | |
| Fuel Control | | 2,500 | |
| Governor | | 2,000 | |
| Fuel Pump | | 2,250 | |
| Fuel Nozzle | | 2,500 | |
| Compressor Bleed Valve | | 1,500 | |
| Starter / Generator | | 1,200 | |

NOTES:

Detailed maintenance / inspection information is provided in the Handbook of Maintenance Instruction, Rotorcraft Flight Manual, and Supplier Technical Publications (i.e., Rolls-Royce).

- ① Bearing grease re-pack task.
- ② Every 600 hours up to 4200 hours then every 300 hours after.
- ③ With cargo hook operation.
- ④ Engine inspection intervals at 100, 150, 300, 600, 1000, and 1500 hours are detailed in the corresponding Rolls-Royce Maintenance Manual.
- ⑥ Value represents hours / cycles.
- ⑦ Hot section inspection.

7.2 Servicing

The MD 500E was designed for ease of maintenance, incorporating built-in features that eliminate support equipment and aid servicing. These features include:

- Spring loaded doors that provide engine and main rotor head access (refer to figure below)
- Quick access panels
- Integrated engine water wash system



The MD 500E has Built-in Steps to Provide Access to the Main Rotor Head without External Ground Support Equipment

The MD 500E helicopter has been designed for servicing and operation using common, commercially-available compounds. Servicing locations are shown in the figure below. Servicing is performed in accordance with the corresponding equipment maintenance manuals. Servicing intervals are detailed in the MD 500E Handbook of Maintenance Instructions. Capacities and compounds used to service the MD 500E are listed in the table on the following page.

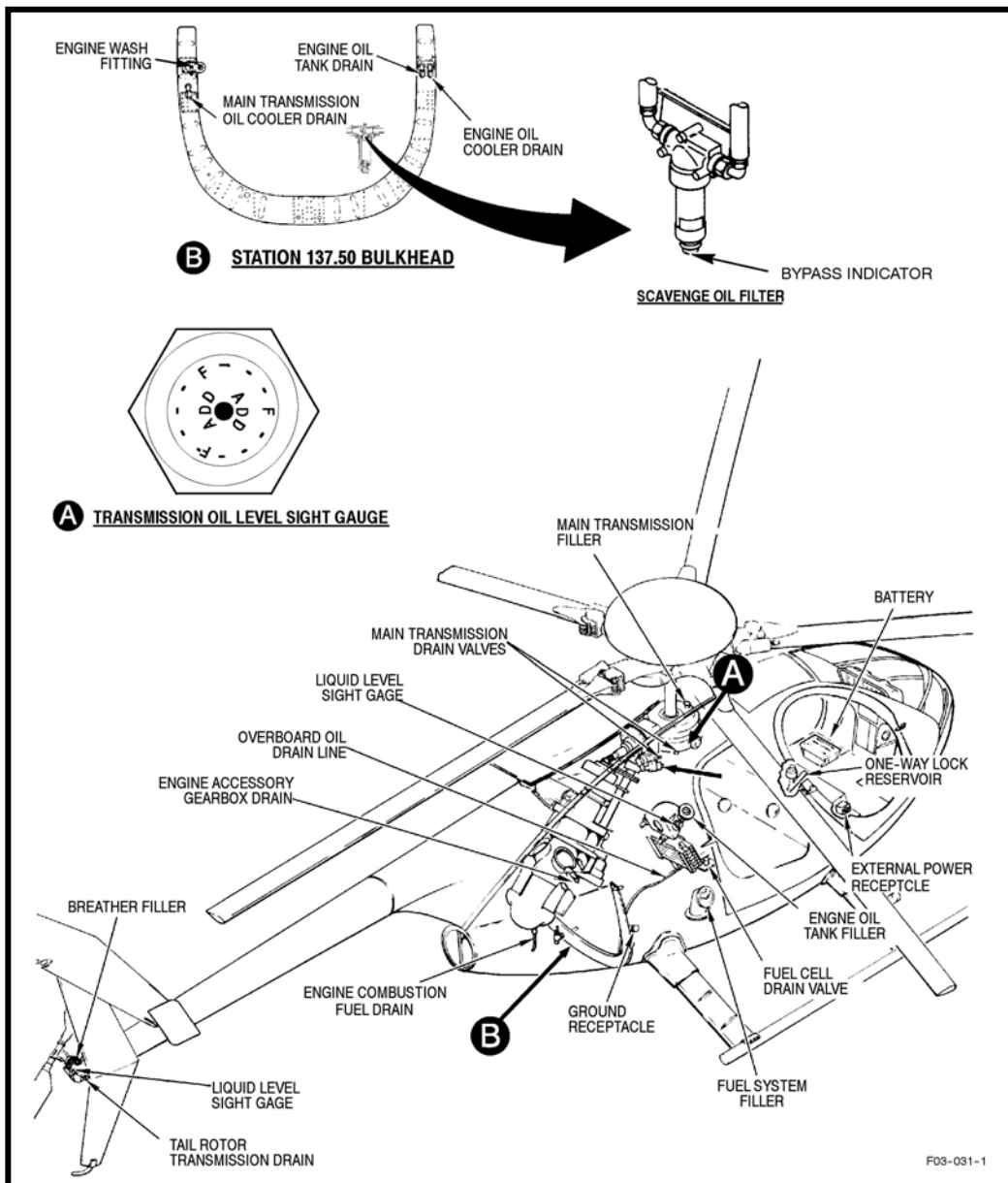

MD 500E Servicing Location Points



MD 500E Fluid Capacities and Specifications

| Component | Compound | Capacity | Specification | Notes |
|--|--------------------|--|--|-------|
| Engine | Lubricant | 3.0 quarts (2.84 liters) | MIL-PRF-7808G / MIL-PRF-23699C | ① ② |
| Overrunning Clutch | Lubricant | 3.64 ounces (107 cc) | Mobil AGL | |
| Main Rotor Transmission | Lubricant | 14.0 pints (6.62 liters) | Mobil AGL | |
| Tail Rotor Transmission | Lubricant | 0.5 pints (0.23 liters) | Mobil AGL | |
| One-Way Lock | Lubricant | 0.67 ounces (20 cc) | MIL-PRF 5606 / MIL-PRF-6083 | |
| Battery | Distilled Water | As Required | MS36300 | |
| Fuel Cell | Fuel | 64.0 gallons (242 liters) 416 pounds | ASTM-D-1655 Jet A ASTM-D-1655 Jet A-1 ASTM-D-1655 Jet B ASTM-D-1655 JP-1 ASTM-D-1655 RP-3 ASTM-D-6615 Jet B MIL-DTL-5624 JP-4 MIL-DTL-5624 JP-5 MIL-DTL-83133 JP-8 | ③ ④ |
| <p>NOTES:</p> <p>① Refer to Rolls-Royce Operation and Maintenance Manual for approved oils</p> <p>② Oil specification type mandated by ambient temperature. Refer to Rolls-Royce Operation and Maintenance Manual.</p> <p>③ Refer to Rolls-Royce Operation and Maintenance Manual for complete fuel specifications.</p> <p>④ At 40F and below, fuel must contain anti-icing additives per MIL-I-27686. Refer to Rolls Royce Operation and Maintenance Manual.</p> | | | | |

7.3 Hourly Cost

Current, estimated direct operating cost per operating hour data using the Rolls-Royce Model 250-C20B and Rolls-Royce Model 250-20R/2 are shown in the following tables, respectively. This data is based on “current-year” 2021 U.S. dollars.



**MD 500E Estimated Direct Cost Per Hour Using Model 250-C20B
Turboshaft Engine is Based on Current-Year (2021) U.S. Dollars**

| Activity | Cost, U.S. Dollars (\$) | Total |
|---|-------------------------|-----------------|
| Rolls-Royce Model 250-C20B | | |
| Fuel and Lubricants^① | | |
| Fuel at \$4.26 per gallon at approximately 27 gallons per hour | \$115.02 | |
| Lubricants at 3-percent of fuel | \$3.45 | |
| | | \$118.47 |
| Airframe Maintenance and Spares^② | | |
| <u>Maintenance Labor Cost:</u> | | |
| Scheduled (0.4 man-hour per flight hour) at \$106.00 per hour | \$42.40 | |
| Unscheduled (0.26 man-hour per flight hour) at \$106.00 per hour | \$27.56 | |
| | | \$69.96 |
| <u>Spares Cost:</u> | | |
| Scheduled (Inspection) Parts: Used during Periodic Inspection (e.g., filters, seals, o-rings, etc.) | \$5.78 | |
| On-Condition / Unscheduled Parts | \$21.12 | |
| Reserves: Component Overhaul (Time Between Overhaul) | \$66.30 | |
| Reserves: Limited-Life Parts | \$57.70 | |
| | | \$150.90 |
| Engine^③ | | |
| Scheduled Maintenance Labor and Parts | \$3.50 | |
| Reserve for Engine Overhaul, Spares, and Accessories | \$89.23 | |
| | | \$92.73 |
| TOTAL DIRECT OPERATING COST^④ | | \$432.06 |

NOTES:

- ① Fuel cost and labor rate is based on U.S. average cost while operating under the following conditions:
 Gross Weight: 10-percent less than maximum certified
 Speed: Maximum range speed, 117 kias
 Altitude: 1,000 feet (304 m) on a standard day.
- ② Overhaul costs are based on participation in factory exchange program.
- ③ Engine fleet maintenance costs provided by Rolls-Royce Engine Company.
- ④ Indirect costs such as insurance, hangar, salary, etc. are not included.

Actual costs will vary, depending on local operating conditions, pricing, and supplier practices.



**MD 500E Estimated Direct Cost Per Hour Using Model 250-C20R/2
Turboshaft Engine is Based on Current-Year (2021) U.S. Dollars**

| Activity | Cost, U.S. Dollars (\$) | Total |
|---|-------------------------|-----------------|
| Rolls-Royce Model 250-C20R/2 | | |
| Fuel and Lubricants^① | | |
| Fuel at \$4.26 per gallon at approximately 29 gallons per hour | \$123.54 | |
| Lubricants at 3-percent of fuel | \$3.71 | |
| | | \$127.25 |
| Airframe Maintenance^② | | |
| Maintenance Labor Cost | | |
| Scheduled (0.4 man-hour per flight hour) at \$106.00 per hour | \$42.40 | |
| Unscheduled (0.26 man-hour per flight hour) at \$106.00 per hour | \$27.56 | |
| | | \$69.96 |
| Spare Parts | | |
| Scheduled (Inspection) Parts: Used during Periodic Inspection (e.g., filters, seals, o-rings, etc.) | \$5.78 | |
| On-Condition / Unscheduled Parts | \$21.12 | |
| Reserves: Component Overhaul (Time Between Overhaul) | \$66.30 | |
| Reserves: Limited-Life Parts | \$57.70 | |
| | | \$150.90 |
| Engine^③ | | |
| Scheduled Maintenance Labor and Parts | \$3.00 | |
| Reserve for Engine Overhaul, Spares, and Accessories | \$90.80 | |
| | | \$93.80 |
| TOTAL DIRECT OPERATING COSTS^④ | | \$441.91 |

NOTES:

- ① Fuel cost and labor rate is based on U.S. average cost while operating under the following conditions:
 Gross Weight: 10-percent less than maximum certified
 Speed: Maximum range speed, 117 kias
 Altitude: 1,000 feet (304 m) on a standard day.
- ② Overhaul costs are based on participation in factory exchange program.
- ③ Engine fleet maintenance costs provided by Rolls-Royce Engine Company.
- ④ Indirect costs such as insurance, hangar, salary, etc., are not included.

Actual costs will vary, depending on local operating conditions, pricing, and supplier practices.



8. PRODUCT SUPPORT

MD Helicopters, Inc. is dedicated to successful fielding, training, warranty support, and customer support of MDHI aircraft. MD Helicopters, Inc. has worldwide service centers and field service representatives available for localized support.

8.1 Training

The MDHI commercial training center offers cost-effective, factory-designed transition-flight and maintenance-crew training courses for MDHI-manufactured helicopters. This training, conducted by senior instructors with extensive product experience, provides customers / students with the detailed knowledge of MDHI products that will increase safety, reduce insurance costs, and result in more efficient operation of the aircraft. Training is conducted at the MDHI facility in Mesa, Arizona. Training using customer aircraft can also be arranged provided insurance, meeting MDHI requirements, is available.

8.1.1 Pilot Training

Transition flight, maintenance test, and recurrent pilot training are available from MDHI. Flight transition pilot training for one pilot is included as part of each MDHI helicopter purchase.

8.1.2 Transition Flight Training

The transition flight training course is designed to familiarize a rated helicopter pilot with operation of the MDHI aircraft. The transition flight training course is a five-day course that introduces the student to all the associated company publications, as well as detailed explanations of all aircraft systems and daily / preflight procedures. The ground school requires 16 to 20 hours to complete, including examination and examination review. The student is expected to pass the examination, demonstrating basic knowledge of the aircraft. The transition flight training syllabus includes six hours of instructor time and is provided in four flight lessons:

- Normal operations
- Advanced operations (maximum gross weight flight)
- Maintenance and systems operations
- Emergency / malfunction procedures.

8.1.3 Recurrent Flight Training

Additional, optional, recurrent pilot training is available for existing MD 500E pilots. Recurrent pilot training provides a pilot review of MD 500E helicopter systems and operations, and uses flight review, proficiency checks, or other checks to review rules, maneuvers, and procedures to demonstrate existing pilot skills. Training is conducted over a three-day period and consists of ground school and two to three hours of flight time. Ground school training includes a review and discussion of airworthiness directives and notices, helicopter systems, flight manual review, preflight inspection, followed by an open-book exam.



8.1.4 Maintenance Training

The airframe maintenance course familiarizes a licensed aircraft and powerplant mechanic with the maintenance and inspection of aircraft major systems. Training adheres to original equipment manufacturer standards and includes an overview of supporting maintenance documentation, service bulletins, service letters, and maintenance logbook. All training materials required to conduct maintainer training (i.e., instructional materials, handouts, presentations, training guides / aids, tests / exercises) are returned to each trainee. Hands-on training using MDHI- or customer-furnished equipment will be provided as necessary to supplement the classroom instruction. Training instruction and technical information are conducted in the English language. Course syllabus includes:

- Airframe
- Flight control system
- Environmental control system
- Power train
- Rotor system.

Maintainer training for one maintainer is provided as part of the helicopter purchase.

8.2 Warranty

The MD 500E commercial helicopters are covered by a commercial warranty which is administered by MDHI Mesa, Arizona. Supplier products (e.g., turboshaft engine, avionics, etc.) are separately warranted through the product supplier.

The MDHI commercial warranty is a materials and workmanship type warranty that begins upon customer helicopter / spare parts acceptance / delivery. The customer will perform prompt repair or replacement of helicopter specific discrepant hardware. For warranty claims pertaining to aftermarket spare parts and components, the customer, at their option (with prior approval), either:

- Returns the non-conforming or defective part or component for credit or refund; or
- Requests correction or replacement of the affected part or component. Associated shipping costs shall be shared by the customer and the vendor.

8.2.1 Warranty Claims

All warranty claims begin with completion of an MDHI service and operations report (SOR) document. The completed SOR document is submitted to MDHI field services for technical accuracy and completeness review and to determine if additional action is needed. When the review is completed, the SOR is forwarded to the MDHI warranty / repair department for determination of warranty claim status. The circumstances of the failure, aircraft and component time, date of submittal and nature of the claim, and other factors, are evaluated in accordance with the current published MDHI warranty. The limited commercial warranty (CSP-A-2) and SOR forms can be accessed through the MDHI website.



8.3 Service Centers

MD Helicopters, Inc. has approved service centers located worldwide. The figure below shows MDHI worldwide approved service centers locations. Detailed service center information is available on the MD Helicopters website.

8.4 Field Service

Dedicated Field Service Representatives are available to support fielded MDHI products. Field Service Representatives are available for the following locations:

- Asia / India / Australia / New Zealand
- Eastern North America
- Middle East / Africa
- Mexico / Central America / South America
- Russia / Commonwealth of Independent States
- Western North America.

