

MISSION PROVEN | LAW ENFORCEMENT | UTILITY



MD 530F

SPECIFICATIONS



Publisher's Notice

This Product Specification includes information that is the property of MD Helicopters, Inc. (MDHI). It provides general information for evaluation of the design, equipment, and performance of the MD 530F helicopter. The information presented in this Product Specification does not constitute an offer and is subject to change without notice. This proprietary information, in its entirety, shall not be duplicated, used, or disclosed—directly or indirectly, in whole or in part—for any purpose other than for evaluation. MD Helicopters, Inc. reserves the right to revise this Product Specification at any time.

© 2020 MD Helicopters, Inc.

All registered trademarks are the property of their respective owners.

CONTENTS

1	THE MD 530F HELICOPTER.....	1
2	SPECIFICATION SUMMARY.....	7
3	HELICOPTER DIMENSIONS.....	8
4	GARMIN AVIONICS FLIGHT DECK.....	11
5	COMMUNICATION AND NAVIGATION.....	15
6	SEATING AND INTERIORS.....	17
7	MISSION PROFILES.....	22
8	EXTERNAL PAINT SCHEMES.....	26
9	MD 530F STANDARD EQUIPMENT.....	27
10	MD 530F OPTIONAL EQUIPMENT.....	28
11	HELICOPTER PERFORMANCE CHARTS.....	29
12	COST OF OPERATIONS.....	36
13	COMPONENT OVERHAUL.....	38
14	CUSTOMER SUPPORT AND SERVICES.....	40
15	MDHI TRAINING ACADEMY.....	45
	ABBREVIATIONS, ACRONYMS AND SYMBOLS.....	50

1 THE MD 530F HELICOPTER

FULLY INTEGRATED HELICOPTER PLATFORM

The MD 530F helicopter is a five-blade, four-passenger, single engine, single pilot capable, multi-purpose aircraft specifically designed for meeting extreme requirements in hot-temperature, high-altitude operations. The MD 530F uses a single Rolls-Royce 650 shaft horsepower (shp) turboshaft engine, is multi-mission capable, and is currently in use globally by commercial, government, and foreign military operators.

The MD 530F delivers increased operational capabilities, greater mission versatility, and superior performance. In its base configuration, the MD 530F is used for training, utility, or light cargo applications. Optional packages provide the MD 530F with solutions for VIP/Executive charter, law enforcement, search and rescue, medical evacuation and armed military missions. All combined, the MD 530F satisfies any modern requirement for an affordable, easy to maintain helicopter.



The MD 530F Helicopter is engineered for hot-temperature, high-altitude operations.

The MD 530F is a fully integrated helicopter platform capable of meeting the most demanding mission profiles with speed and agility. The powerful Rolls-Royce Model 250 Series IV 250-C30 engine, coupled with a proven main rotor design, provides superior performance in extremely hot temperature and high-altitude environments. The cabin is optionally compatible with night vision goggles (NVGs) and also includes all the required civil and tactical communications and navigation

systems. In addition, the aircraft incorporates an enhanced glass cockpit design with advanced avionics providing intuitive interface between pilot and aircraft.

The MD 530F is certified for single pilot operations under visual flight rules (VFR)/visual meteorological conditions (VMC) and capable of training instrument flight rules (IFR) in VMC conditions. The MD 530F supports two crewmembers on the controls and two observers in the aft cabin. An integrated communication system allows all crewmembers and observers to communicate easily amongst themselves.

The MD 530F's structural design, exceptional visibility, simple controls, and ruggedness are characteristics well suited for a training aircraft. The visibility from the pilot and co-pilot seat is through the large windscreen and side windows, which are made of tinted plexiglass. The dual flight controls allow the pilot and co-pilot, or instructor and student complete, simultaneous access to the aircraft controls and displays. The fuselage is a teardrop-shaped semi-monocoque type construction manufactured primarily of aluminum alloy bulkheads and stringers, with the outer skin of aluminum panels, providing clean aerodynamic lines. The airframe structure is designed to be energy absorbing and fails progressively in the event of impact. The A-frame fuselage design serves as a built-in roll cage to protect the pilot and crew in case of a rollover situation.

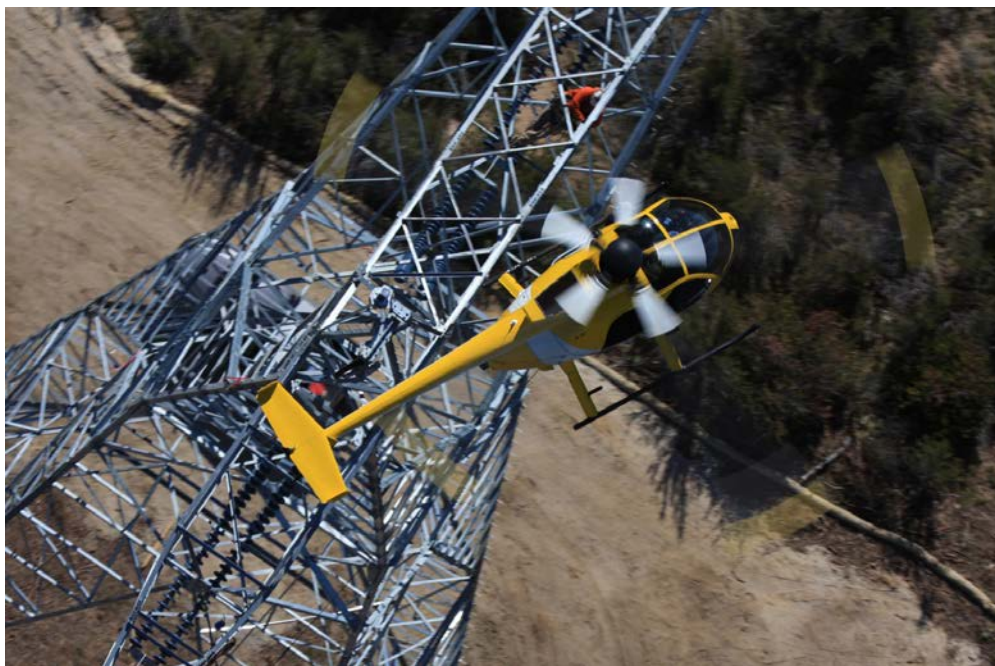

The MD 530F Helicopter delivers the agility and controllability required for a broad range of mission profiles.

FULLY INTEGRATED AVIONICS

In 2016, MDHI added a fully integrated, state-of-the-art electronic flight instrument system (EFIS) upgrade, or “glass cockpit”, to the MD 530F, with all the required primary and multi-function displays for comprehensive flight data and sensor management.

The MD 530F incorporates a modernized instrumentation/avionics cockpit consisting of a Garmin G500H TXi™ suite that includes multi-function and primary flight displays (MFD, PFD) and an engine indicating and crew alerting system (EICAS). The EICAS replaces the analog caution and warning annunciators.

The next-generation electronic flight instrumentation system also works with additional equipment, such as a Garmin GTN™ 650 GPS/NAV/COMM and automatic dependent surveillance-broadcast (ADS-B), to provide next-generation air transportation system compatibility.



MD 530F Flight Deck — Standard Configuration

MD 530F SPECIFICATIONS



MD 530F Flight Deck – Custom Configured for Airborne Law Enforcement Operations

KEY FEATURES AND BENEFITS

MD 530F Key Features and Benefits	
Airframe	
<ul style="list-style-type: none"> • Simple system design • Mature, field-proven systems and components • Separate cockpit and cabin • 2+2 seating capability • Speed, agility, and load-capable • Certified to 14 CFR Part 27; VFR • Approved/certified in over 40 countries worldwide • External power receptacle 	<ul style="list-style-type: none"> • Integrated landing gear dampers • Fully articulated main rotor blades • Main rotor system removal independent from main rotor transmission • Main rotor transmission removal independent from main rotor system • Proven record of high dependability • High availability
Integrated Safety Features	
<ul style="list-style-type: none"> • Designed for operator ease • Main rotor static mast/base designed to be fail-safe to 100-percent design load • Three-dimensional truss-type structure with integral roll bar • Energy-absorbing airframe with occupant seat crush boxes for 20g shock resistance • Extended, energy-attenuating landing gear • Dual, crash-resistant elastomeric fuel cells mounted between crash-resistant keel beams and bulkheads below the cabin floor 	<ul style="list-style-type: none"> • Empennage mounted tail skid • Shoulder/seat belts attached to primary structure • Engine mounted low and at the rear • Fire wall separation from passenger/ crew • Fuel filter automatic bypass if filter becomes restricted • Crew seats with 4-point restraints • Passenger seats with 3-point restraints • Integrated visual/audible warning indication for flight critical functions
Supportability Features	
<ul style="list-style-type: none"> • Modular system design • Designed for ease of maintenance and supportability • Designed for reparability • Low direct operating costs • Maximum use of line replaceable units: <ul style="list-style-type: none"> — Engine — Avionics/communication — Flight controls — Main rotor blades — Main rotor drive shaft — Main rotor transmission — Main rotor transmission drive shaft — Main rotor mast — Tail rotor gearbox — Tail rotor blades — Landing gear — Canopies — Doors — Door handles — Door windows — Seat restraints — Tail boom — Oil cooler/blower 	<ul style="list-style-type: none"> • Maximum use of line replaceable units (Contd.): <ul style="list-style-type: none"> — Empennage — Tail boom skid • Built-in maintenance aids: <ul style="list-style-type: none"> — Engine fuel and oil filter impending bypass indicators — Engine oil chip detector — Tail rotor transmission oil chip detector — Main rotor transmission oil chip detectors — Engine, main rotor transmission, and tail rotor transmission oil level sight gage — Engine oil filler cap/dipstick — Main rotor transmission filler cap — Integrated engine compressor wash system — Footsteps located on each side for upper deck access without ground support equipment — Landing gear ground handling wheel quick attach feature

MD 530F SPECIFICATIONS

MD 530F Key Features and Benefits	
Human Systems Integration Features	
<ul style="list-style-type: none"> • Unobstructed forward 160-degree vertical and 220-degree horizontal cockpit field of view • Cockpit designed to accommodate 25th to 95th percentile male/female flight crew • Integrated cockpit and cabin entry steps 	<ul style="list-style-type: none"> • Tail rotor drive shaft labeled for assembly ease/installation error proofing • Integrated visual/audible warning indication for flight critical functions
Engine	
<ul style="list-style-type: none"> • Fuel efficient, field-proven, turboshaft engine 	<ul style="list-style-type: none"> • Externally accessible water wash system
Monitoring Instrumentation	
<ul style="list-style-type: none"> • EICAS; caution and warnings are indicated on EICAS displays 	<ul style="list-style-type: none"> • Double redundant EICAS and PFD/MFD • Independent L3Harris ESI-500 Electronic Standby Indicator

CERTIFICATION

MD 530F is the commercial designation for the model 369FF helicopter, currently in production for numerous commercial and military customers. The MD 530F (369FF) is certified by the United States Federal Aviation Administration (FAA) Code of Federal Regulations (CFR) Title 14, Part 27 under Type Certificate number H3WE with attendant Type Certificate Data Sheet.

2 SPECIFICATION SUMMARY

MD 530F PERFORMANCE SPECIFICATIONS

MD 530F Performance Specifications			
Characteristics At Design Gross Weight	Condition		
Maximum Cruise Speed	Sea Level	113 kt. (130 mph)	209 km./hr.
	1,524 m. (5,000 ft.)	110 kt. (127 mph)	204 km./hr.
Maximum Range Speed	1,524 m. (5,000 ft.)	98 kt. (113 mph)	181 km./hr.
Maximum Permitted Speed	V _{NE} at Sea Level	152 kt. (175 mph)	282 km./hr.
Maximum Range	Sea Level	194 NM (223 mi.)	359 km.
	1,219 m (4,000 ft.)	218 NM (251 mi.)	404 km.
	1,524 m. (5,000 ft.)	223 NM (257 mi.)	413 km.
Maximum Endurance	Sea Level	2.36 hrs.	2.36 hrs.
Maximum Rate of Climb	Sea Level, Standard Day	1,031 ft./min.	5.2 m./sec.
Maximum Operating Altitude	Density Altitude	16,000 ft.	4,877 m.
Maximum Hook Capacity		2,000 lb.	907 kg
Hovering Performance (No wind)			
In-ground Effect	Standard Day	14,280 ft.	4,353 m.
	ISA +20°C Day	12,970 ft.	3,953 m.
Out-of-ground Effect	Standard Day	11,140 ft.	3,395 m.
	ISA +20°C Day	8,750 ft.	2,667 m.
Weights		Imperial	Metric
Maximum Gross Weight	Normal Capacity	3,350 lbs.	1,519 kg.
	External Load Operations	3,750 lbs.	1,701 kg.
MD 530F Empty Weight	Standard Configuration	1,723 lbs.	782 kg.
MD 530F Useful Load	Internal Load	1,627 lbs.	738 kg.
	External Load	2,027 lbs.	919 kg.
Main Fuel Tank; Crash Resistant Fuel System	229 liter 60.5 gal	Empty – 35.2 lbs.	Empty 16 kg.
		Full (Jet A) 447 lbs.	Full (Jet A) 203 kg.
Aux Tank - Robertson	125 liter (33 gal.)	Empty 56 lbs.	Empty 25 kg.
		Full (Jet A) 277 lbs.	Full (Jet A) 126 kg.
Power Plant			
Rolls-Royce Model 250 IV-C30 Gas Turbine	Rated Power	650 shp	478 kW
Derated Power for Reliability and Safety	Transmission Rating	425 shp	313 kW
	Max Continuous	350 shp	257 kW

3 HELICOPTER DIMENSIONS

EXTERNAL DIMENSIONS

MD 530F External Dimensions	
Fuselage Width	4.57 ft. (1.40 m)
Fuselage Length	23.88 ft. (7.28 m)
Horizontal Stabilizer Width	5.43 ft. (1.66 m)
Landing Skid Width	6.45 ft. (1.97 m)
Ground to Rotor Height	8.65 ft. (2.64 m)
Ground to Fuselage Bottom Height	1.77 ft. (0.54 m)
Main Rotor Diameter	27.50 ft. (8.38 m)
Tail Rotor Diameter	5.08 ft. (1.55 m)

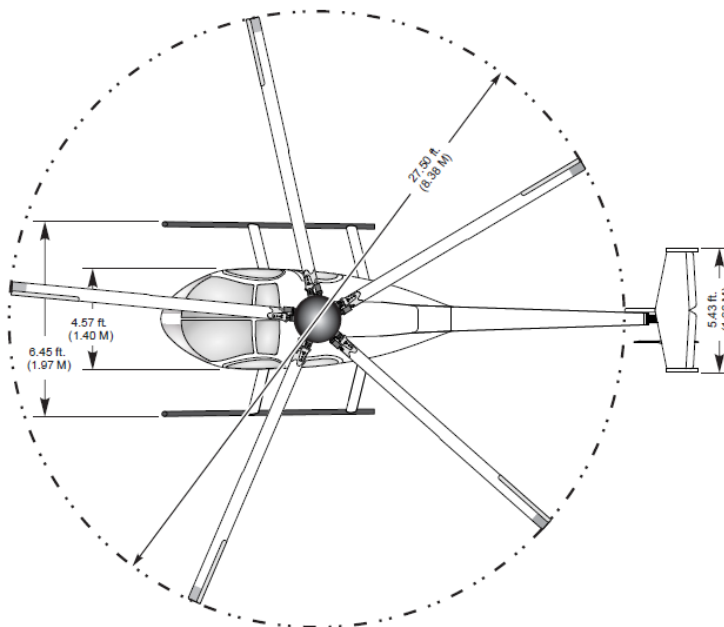
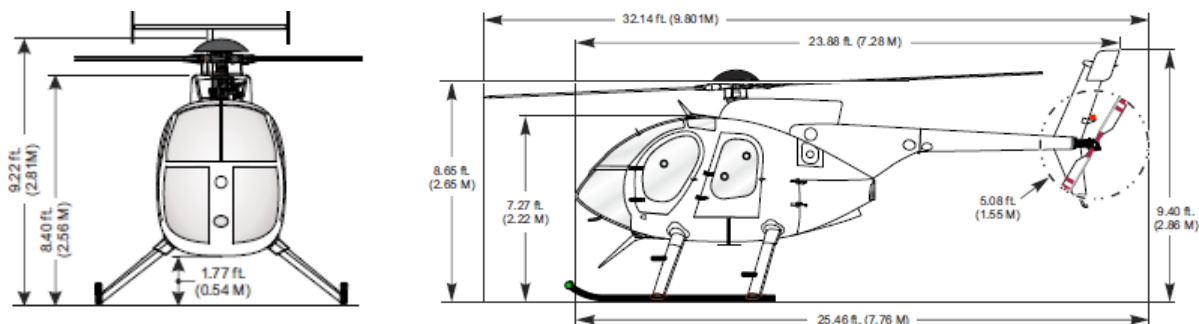

MD 530F Principal Dimensions
(shown with standard extended landing gear)

INTERNAL DIMENSIONS

MD 530F Internal Dimensions		
Crew Compartment Width	(A)	49.00 in (124.50 cm)
Crew Seat to Instrument Panel	(B)	18.50 in (47.00 cm)
Crew Compartment Depth	(C)	37.50 in (95.30 cm)
Passenger Seat to Front Bulkhead	(D)	19.00 in (48.30 cm)
Passenger Compartment Depth	(E)	29.00 in (73.70 cm)
Passenger Compartment Width	(F)	44.50 in (113.00 cm)
Aft Cabin Volume	(E x F)	38.2 cubic ft. (1.1 cubic meter)

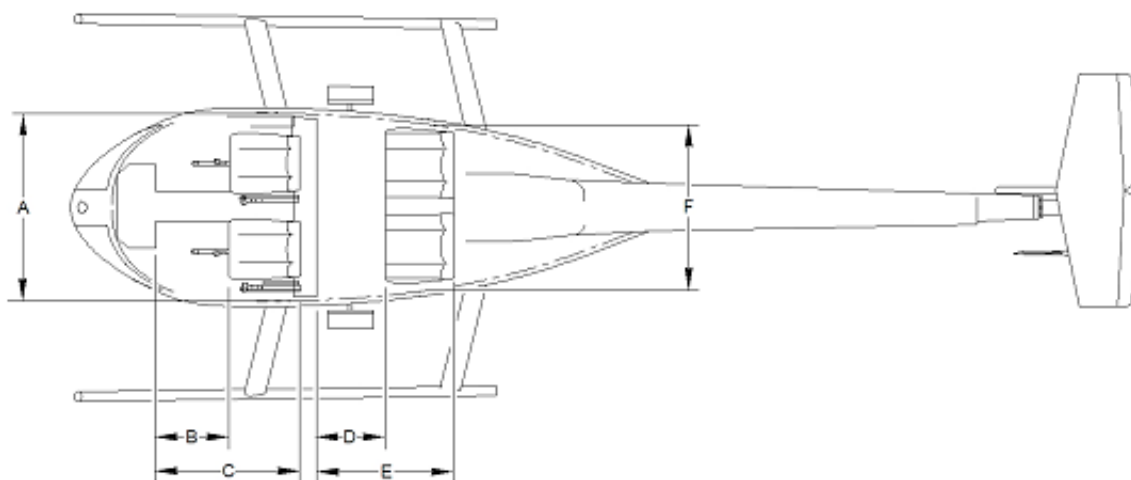

MD 530F Internal Dimension Locations

COCKPIT INSTRUMENT PANEL AND SLANT PANEL DIMENSIONS

MD 530F Instrument Panel and Slant Panel Dimensions	
Cockpit Instrument Panel Width	22.00 in (55.90 cm)
Cockpit Instrument Panel Height	14.00 in (35.60 cm)
Slant Panel Length	14.30 in (36.30 cm)
Slant Panel Width	6.30 in (16.00 cm)

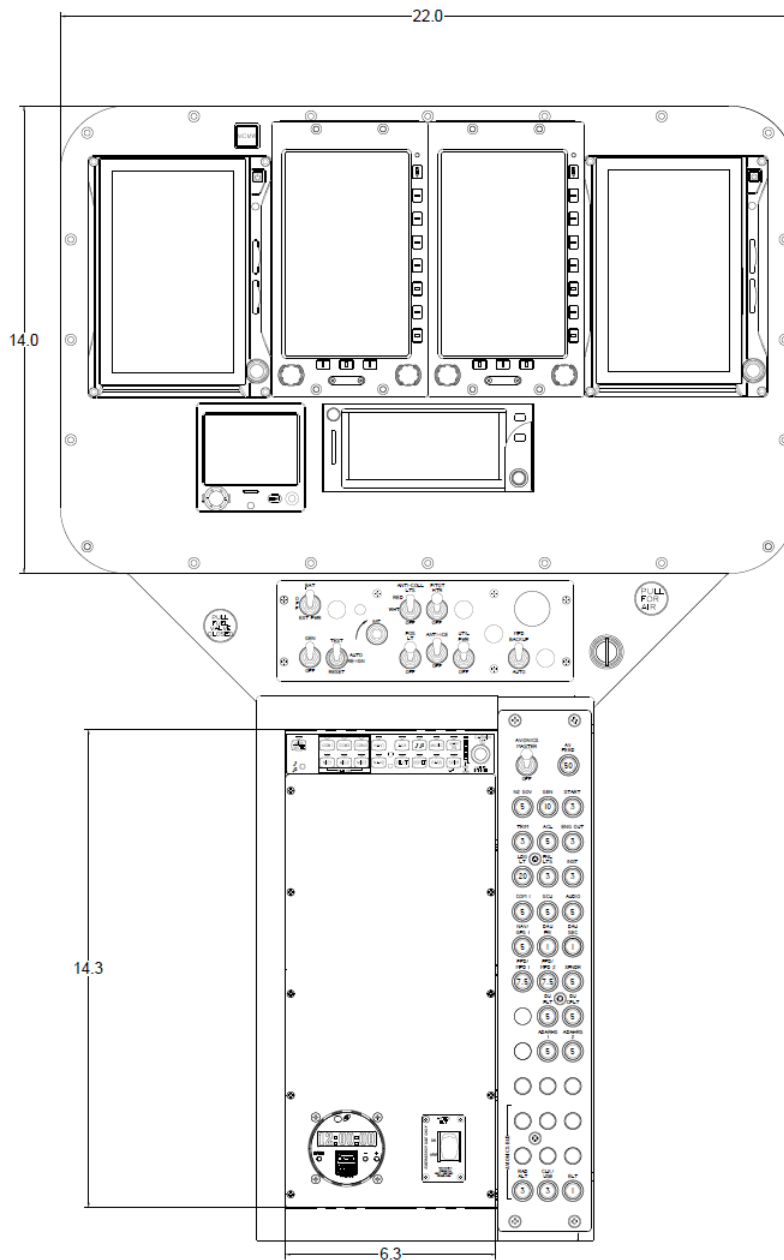

*MD 530F Cockpit Instrument & Slant Panel
(front view width and height)*

4 GARMIN AVIONICS FLIGHT DECK

MD 530F GLASS COCKPIT CONFIGURATION

The MD 530F aircraft is outfitted with MDHI's advanced glass cockpit design, which supports maximum visibility for the pilot and co-pilot. Using the latest display technology, the pilot maintains the ability to manage navigation, communication, and aircraft systems. The configuration is certified for day/night operations, and a night vision compatible cockpit is an available option. The design update modernizes the cockpit, and provides added redundancy and enhanced safety features, effectively reducing pilot workload. The cockpit is available in a left-hand or right-hand command configuration depending on specific customer mission requirements.

The glass cockpit includes a Garmin G500H TXi™ integrated display system that uses a dual display unit to serve as the PFD and MFD. The G500H TXi™ system replaces the analog airspeed and altimeter indicators, modernizing the cockpit and providing redundancy and enhanced safety features. Dual Howell Instruments displays make up the EICAS, which replace the analog engine instruments and caution advisory panel. Navigation and communication functions are provided by the Garmin GTN™ 650H liquid crystal display, allowing for moving maps and airways and approach procedures.

Situational awareness (SA) can be enhanced significantly by activating the optional Garmin Helicopter Synthetic Vision Technology (HSVT™) and helicopter terrain awareness and warning system (HTAWS) capabilities of the Garmin G500H TXi™ display system.



*Glass Cockpit with Howell Instruments Engine Instruments Display, Garmin G500H TXi™ MFD/PFD, L3Harris ESI-500 and GTN™ 650H.
(optional equipment also depicted)*

GARMIN G500H TXi™

Major components of the Garmin G500H TXi™ are:

- Two GDU 700P PFD/MFD Units
- GMA™ 350H Audio Panel
- Two GMU 44 Magnetometers
- UTC Aerospace Systems Series 0129G Outside Air Temperature (OAT) Probe
- GTP 59 OAT Probe
- Two GSU 75 Air Data Attitude and Heading Reference Systems (ADAHRS)
- GTN™ 650 GPS/NAV/COMM
- GTX 345R Remote Mount ADS-B IN/OUT Transponder

Other integrated components include:

- Avionics Master Switch
- Emergency Locator Transmitter (ELT) 406 MHz
- Free Flight RA-4500 Radar Altimeter



Garmin GDU 700P Touchscreen Displays PFD/MFD

ENGINE INSTRUMENT AND CREW ALERTING SYSTEM (EICAS)

The EICAS consists of:

- **Two Howell Instruments Display Units (HDUs)**

The HDUs are high-resolution, portrait-oriented, 7" color LCD displays that contain user controls. Each HDU has a normal display mode and a reversionary (REV) display mode. The normal display mode contains two pages, Primary and Secondary. Warning and caution indicators, located at the top of the Secondary page HDU, provide crew alerting. The REV display mode combines all the instruments (except the outside air temperature (OAT) digital value) and annunciations on one display. REV mode provides redundancy if one display fails.

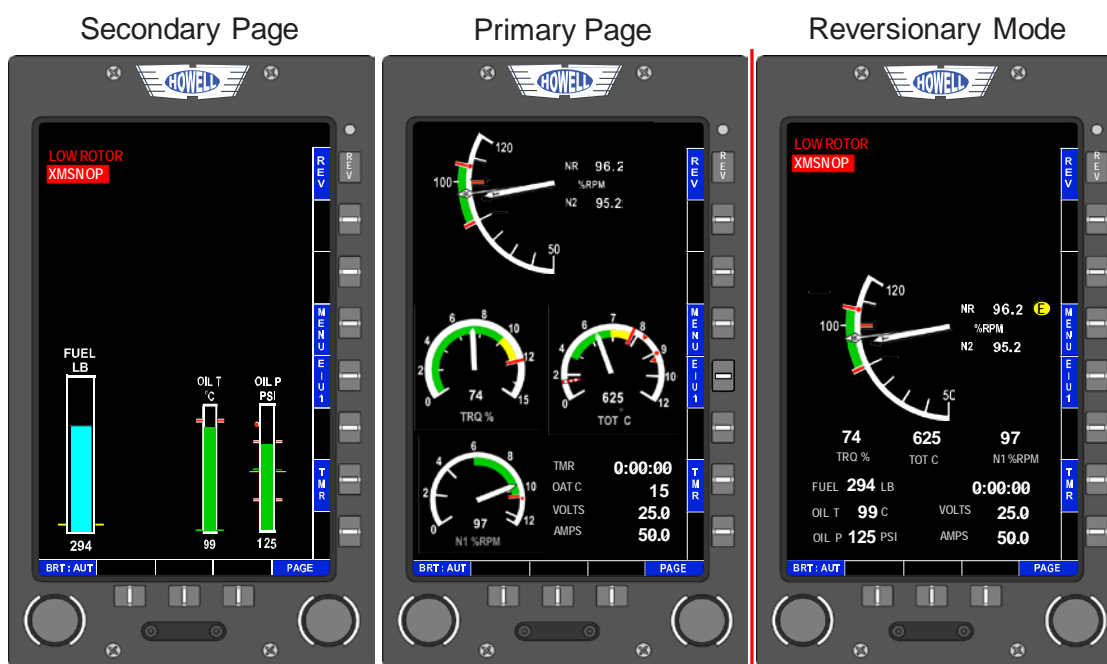

HDU normal display mode (primary and secondary pages) and reversionary display mode.

- **Configuration Module Unit (CMU)**

The CMU is a personality module, which stores specific installation information for the data acquisition unit (DAU), to determine parametric data such as engine type, aircraft type and optional installed aircraft sensors. The CMU also retains calibration data of the fuel system.

- **Data Acquisition Unit (DAU)**

The DAU contains two processor cards called engine instrument units (EIUs). Each EIU gathers engine and aircraft sensor data for display on the HDU. The EIUs (EIU 1 and EIU 2) are redundant backups to each other, which an operator can select during flight using the hot key on the HDU.

The EICAS eliminates the need to run “wet lines” to the cockpit for engine instrumentation.

L3HARRIS ELECTRONIC STANDBY INDICATOR

L3Harris' Next-Generation Electronic Standby Instrument System – ESI-500 is one of the most advanced standby instruments designed specifically for helicopters. The compact unit is scalable and comes standard with altitude, attitude, slip/skid, vertical speed and aircraft track. Options are available for the display of navigation information and synthetic vision (SynVis), including terrain and obstacles. The ESI-500 is compatible with existing NAV radios and GPS hardware. An internal lithium-ion battery pack automatically powers the system without interruption upon loss of main input power.



L3Harris ESI-500

5 COMMUNICATION AND NAVIGATION

The standard communication and navigation avionics system for the MD 530F includes:

- **Audio System:**
 - **GTN™ 650 GPS/NAV/COMM Audio System:** With GPS navigation, COMM and NAV capabilities all built into the brand new Garmin GTN 650, pilots are finding the GTN 650 cannot be beat for value, features, and quality. The GTN 650 is a compact 2.64 in. tall package. The new touchscreen of the GTN 650 offers many multi-purpose functions and features, such as high-resolution landscape mapping, graphical flight planning, satellite weather, targeted traffic display and more. Aircraft pilots are embracing the new touchscreen and navigation found only on the Garmin GTN 650.
 - **GMA™ 350H Audio Panel:** The GMA 350H Audio Panel from Garmin provides the traditional audio selector functions of microphone and receiver audio selection. The audio panel includes an intercom system (ICS), a marker beacon receiver, and a COMM clearance recorder. Ambient noise from the aircraft radios is reduced by auto squelch (ASQ). When no audio is detected, ASQ processing further reduces the amount of background noise.



- **2020 FAA-compliant ADS-B Transponder:**
 - **GTX™ 345R ADS-B In/Out Transponder:** With the introduction of the GTX 345R remote-mounted Mode S Extended Squitter (ES) transponder, Garmin provides the ideal upgrade path for aircraft operators looking to satisfy NextGen requirements for ADS-B “Out” – while providing all the weather and traffic benefits of ADS-B “In” with select G1000, GTN 750/650 and other third-party avionics. The GTX 345R is also optionally available with a built-in Wide Area Augmentation System (WAAS) GPS position source, so everything needed to meet ADS-B equipage rules for NextGen airspace can be provided with this all-in-one upgrade package installation.

- **Software Features:**

- Garmin GTN™ and TXi™ navigation cards (customer selectable)

Communication and navigation avionics systems available to be activated on the MD 530F are:

- Garmin HSVT™
- Garmin HTAWS
- GTN 16W enablement card
- Night Vision Imaging System (NVIS) compatibility

6 SEATING AND INTERIORS

CREW SEATING

The MD 530F cockpit accommodates the pilot and co-pilot or passenger. The minimum crew is one pilot in the command position. Seats are constructed of padded upholstered material and are attached to the forward bulkhead. A bulkhead behind the forward compartment separates the cockpit and passenger/cargo compartment. Optional aluminum tube frame and black mesh seats or leather seats are also available.



PASSENGER SEATING AND CARGO COMPARTMENT

The passenger/cargo compartment of the MD 530F provides space for passengers, cargo, or multi-mission equipment. The rear portion of the passenger/cargo compartment provides increased headroom and visibility. Standard seats are constructed of padded upholstered material and are attached to the rear bulkhead. Optional aluminum tube frame black mesh seats, leather seats, or the bench style seat are also available.

Seats may be easily folded out of the way or completely removed to accommodate cargo. During cargo carrying operations, the compartment floor serves as the cargo deck. Removable and interchangeable cargo tie-down fittings are available.



AIRCRAFT ACCESS

Four doors are installed on the helicopter, two on each side. The two forward doors permit access to the forward compartment for pilot and co-pilot or passenger. The two aft doors allow entry to the passenger/cargo compartment. Transparent tinted windows are contained in the doors. Doors can be quickly removed and the helicopter flight-operated without the doors.



FUSELAGE

The MD 530F fuselage is a teardrop-shaped, aerodynamically efficient structure that incorporates a high horizontal stabilizer. The fuselage is a semi-monocoque construction, manufactured primarily of aluminum alloy. It consists of a rigid, three-dimensional truss type structure, with an integral roll bar design, for increased occupant safety. The airframe structure is designed to be energy absorbing and fails progressively in the event of impact. Occupant seat crush boxes are incorporated into the design and provide 20g shock resistance.

The airframe includes doors for the pilot, co-pilot, and passenger/cargo area on both sides that can be quickly removed for flight.

The fuselage structure, shown in the figure below, is divided into three main sections:

- A. Forward/Upper Fuselage:** Comprised of a pilot compartment and, directly aft separated by a bulkhead, a passenger / cargo compartment. The pilot compartment is equipped with seats and dual controls for the pilot and a co-pilot, or with co-pilot controls removed. The passenger / cargo compartment, located in the center of the aircraft, contains provisions for installation of a bench or individual folding-type seats for up to two passengers.
- B. Lower Fuselage:** Divided by the center beam and provides the housing for the two fuel cells. Provisions for the attachment of a cargo hook are located on the bottom of the fuselage in line with the center beam. The lower fuselage structure extends beneath the pilot floor and contains compartment space for the aircraft battery and provision for small cargo storage or installation of avionics equipment.
- C. Aft Fuselage:** Includes the structure for the tail boom attachment and engine compartment. The engine compartment is accessible through two clamshell doors contoured to the shape of the fuselage.

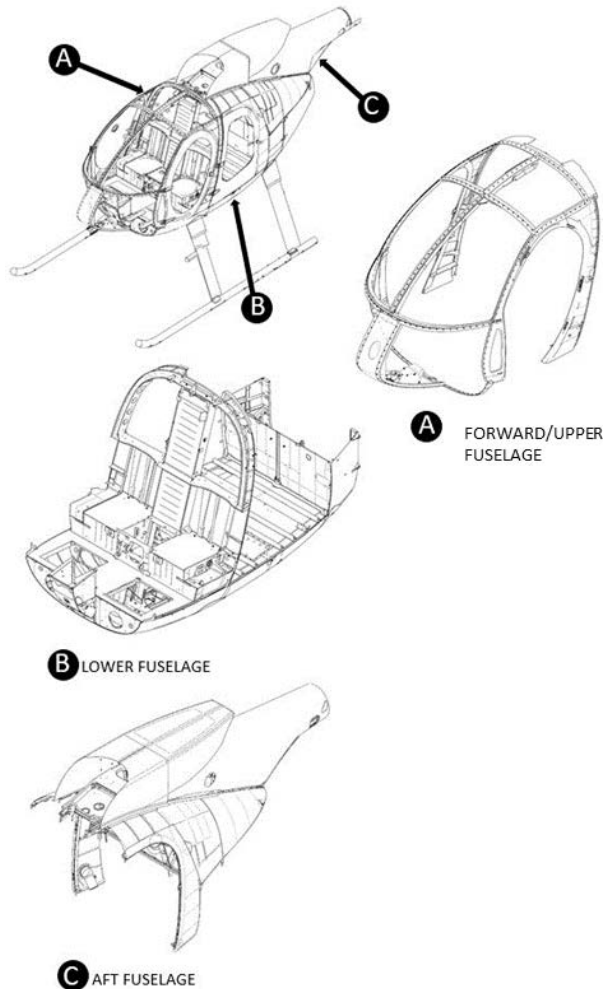

Aircraft Crashworthiness

The MD 530F provides important fail-safe characteristics concerning crashworthiness. Tests on the landing gear and fuselage sections verified the crashworthiness capability of the MD 530F and all 369-based aircraft. Testing indicates that the MD 530F will provide occupant protection for approximately 95-percent of all civil accidents, and that the landing gear and airframe fuselage is capable of absorbing vertical descents up to 26.3 feet per second with only moderate crewmember injury.

Shoulder and seat belts are attached to the primary structure rather than to the seats. A deep fuselage base structure, including a center beam, in combination with an integral energy absorbing seat base structure provides sufficient yielding depth for maximum energy absorption during a crash impact. This provision, for yielding collapse of the fuselage substructure during a crash and without sudden failure of rigid members, provides exceptional crash safety to the crew long after an initial structure failure resulting from a severe impact.

The basic structure also forms a rugged truss protecting the crew from rotor and transmission collapse or in the event of roll over. The fuel cells are protected in a crash by the double wall bottom, with the closely spaced frames and by the deep center beam. The engine is mounted at a 47-degree angle, and is below and to the rear of the passenger and fuel compartments, thus reducing the possibility of a post-crash fire.

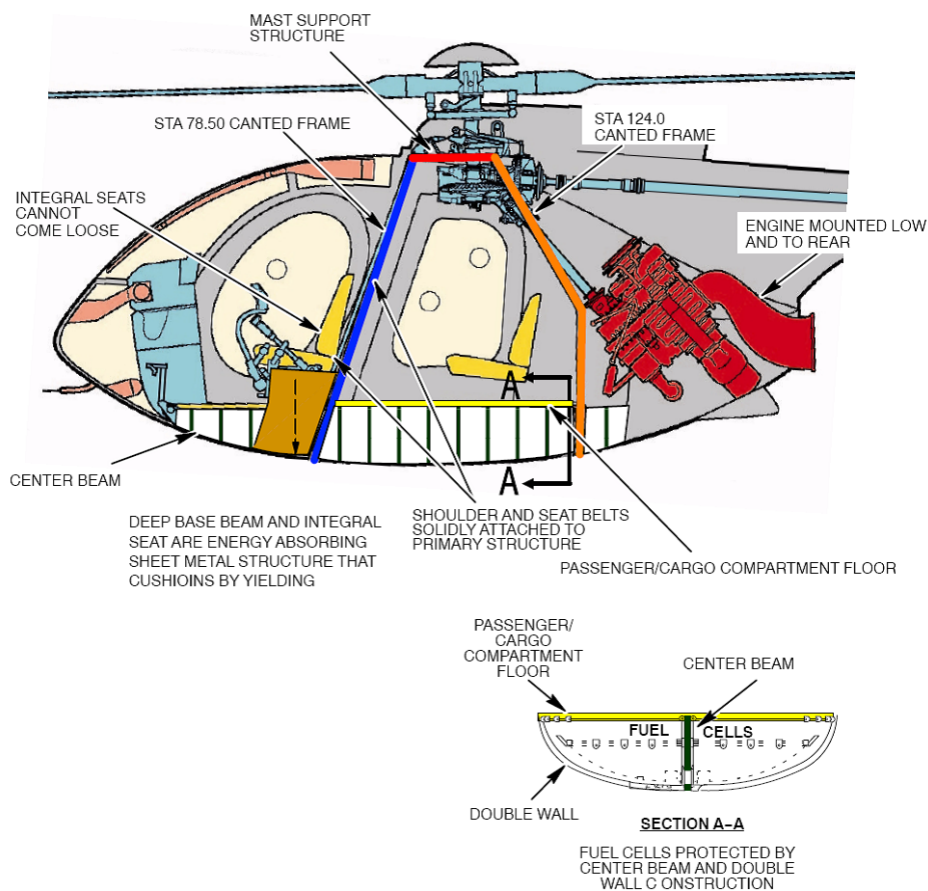

MD 530F Crashworthy Design

7 MISSION PROFILES

The MD 530F is engineered to meet all requirements for hot-temperature, high-altitude operation. Equipped with the 650 shp Rolls-Royce Model 250 Series IV-C30 engine, the MD 530F operates more effectively in hot, high environments than other helicopters in its class. The MD 530F offers the high-level of performance required at a lower cost of ownership in the execution of a broad range of mission profiles.

UTILITY

Technically, it's still work.

From the precision of power line installation and maintenance to agricultural spraying, electronic newsgathering, herding, logging, offshore operations, pest control and general transport, MDHI helicopters are operated worldwide in the performance of a wide range of commercial utility operations.



The multi-mission capable MD 530F capitalizes on its ability to perform a wide range of utility operations.

LAW ENFORCEMENT / PUBLIC SAFETY

High & Mighty

MD Helicopters helped pioneer the airborne law enforcement concept in the 1960's. Today, modern law enforcement requires proven capabilities in technically advanced helicopters that serve and protect the public and provide increased levels of safety to its officers. The MD 530F delivers next generation capabilities in a fast, agile, hot-high proficient helicopter that meets a wide range of law enforcement aviation mission profiles. Featuring advanced avionics and equipment, the MD 530F performs without fail – every time.



The MD 530F, ensuring mission success for airborne law enforcement and public safety operations.

VIP / EXECUTIVE CHARTER

The helicopter pilots buy.

Discerning VIP / Executive charter operators understand that when it comes to meeting the most exacting attention to detail, functionality, sophistication and performance, MDHI delivers class-leading rotorcraft for personal luxury and business travel operations. The MD 530F offers performance and luxury whether serving as executive transport for time-sensitive business trips or for making connections to skyscraper, resort or yacht landing pads.



The "Ferrari of helicopters", the MD 530F is fast, fun to fly and preferred by pilots worldwide.

TRAINING

Fast, agile, affordable and fun to fly.

The MD 530F's structural design, exceptional visibility, simple controls, and ruggedness make it a fantastic training aircraft. Proven and preferred by both commercial and military operators as a versatile and efficient training platform, the 4-place MD 530F is an incredibly robust, affordable turbine helicopter trainer with an unmatched safety record.



Easy and fun to fly, the MD 530F is perfect for a wide range of commercial, military and paramilitary training operations.

8 EXTERNAL PAINT SCHEMES

The MD Helicopters Factory Service Center team is available to paint or repaint any MDHI helicopter. Using an eco-friendly down-draft paint booth, MDHI paint specialists will provide a genuine "baked on" finish that will dazzle and satisfy even the most critical eye, and do it at a competitive price.

Expert design consultation is available as an option. Conversely, at no additional charge, MDHI offers a number of standard layouts from which customers may choose a single color from the available color palette for the MD 530F exterior. Exterior color schemes featuring two, three, or more colors can be painted for an additional cost.



Standard single color paint option



Two-color paint scheme option



Three-color paint scheme option



Custom 3+ color paint scheme

9 MD 530F STANDARD EQUIPMENT

AIRFRAME

Hobbs Meter	Paravion Cockpit Door Openers
Carbide Skid Shoes	Passenger Steps
Engine Wash Kit, MD500-Series	Rain Gutter Set
Extended Landing Gear	Rapid Door Removal Hinges (Cockpit and Cabin)
Fuselage Hard Points	Tinted Canopy Panels
Heated Pitot Tube	Tinted Door/Window Panels
Keyed Locks (4)	One Color Paint (Aircraft Exterior)

INTEGRATED AVIONICS

Howell Instruments Engine Instruments ELT, ME-406HM	L3Harris ESI-500, Electronic Standby Indicator
Garmin G500H TXi™ EFIS	Master System Switch
Garmin GMA™ 350H Audio Panel	MD93 Clock/Timer with USB Charging Ports
Garmin GTX™ 345R, ADS-B In/Out Transponder	PAI-700 Magnetic Compass, Vertical Card
Garmin GTN™ 650H GPS/NAV/COMM	Radar Altimeter RA-4500

ELECTRICAL / LIGHTING

Cabin Convenience Light	LED Position Lights
Cockpit Utility Light	200-amp Starter Generator
Landing Light, Nose Mounted	Concorde Lead Acid Battery
LED Anti-Collision Lights	External Power Receptacle

INTERIOR

Batiflex, Vinyl Flooring	Heater Defogger System
Cabin Soundproofing	Left-hand Rotor Brake
Comfort Kit	Logbook Case
Crew Seats with 4-point Harness Restraint	Passenger Seats with 3-point Harness Restraint
Dual Left-hand Command Flight Controls	Fly Away Kit
Fire Extinguisher	Seat Pan Inspection Panels
First Aid Kit	Slant Panel Pedestal
Fresh Air Ventilation System	

DOCUMENTATION / PUBLICATIONS

Battery Log Book	Flight Manual
Engine and Airframe Log Books	Handbook of Maintenance Instructions
Engine Maintenance Manual	Illustrated Parts Catalog

POWERPLANT

Rolls-Royce Model 250 Series IV-C30, 650shp (485kW)	60.5 Gallon (229 liter) Crash Resistant Fuel System
AFS Engine Inlet Barrier Filter	Engine Anti-Ice
Automatic Engine Re-ignition	Facet Oil Filter

10 MD 530F OPTIONAL EQUIPMENT

AIRFRAME

Comfort Windows	Paravion Cabin Door Openers
Engine Bay Quick Release Hinges	Side External Equipment Mount
Exterior Crew Handles	Weight On Ground (WOG) Actuated (Flight) Hour Meter
LED Landing Light (Flashing and/or Steady)	Thirty-three (33) Gallon Auxiliary Fuel Tank
High-visibility Main Rotor Blades	Twenty-one (21) Gallon Auxiliary Fuel Tank
Military Cyclic Grip	Two or More Paint Colors (Aircraft Exterior)
Nose External Equipment Mount	Shwayder Surfacite Full-length Skid Shoes
Wire Strike Protection Kit	

AVIONICS / ELECTRONICS

Garmin GTN™ 750 GPS/NAV/COMM	External Public Address/Siren System
Garmin GTR 225 (A, B, & NVG)	Nose or Side Mounted FLIR HDc 380 Camera System
Macro Blue 12-inch Display	Nose or Side Mounted Wescam MX10 Camera System
Avalex 12-inch Display	Aero Computers LE 6000 Mapping System
Boland 12-inch Display	Churchill Mapping System
Various Audio Panels (TDAP 611, TDAP 711, AMS-42/44)	Cyclic Remote Frequency Switch
AA-34 Universal Radio Interface	Spectrolab SX-5, SX-16 Searchlight
BMS Helicoder 4	Trakka Beam A800 Searchlight
IMT Skymaster TX Downlink with Omni Controller	Nightscanner Searchlight
TDFM 9300 Radio with P25 Trunking, Encryption, OTAR	
TFM 30 VHF/FM Low Band Transceiver	

MISSION EQUIPMENT

Emergency Water Floats	Onboard Cargo Hook Weighing System
“Float Lamp” Landing Lights	Onboard Cargo Hook (Hydraulic or Mechanical)
External Personnel Bench	Side Pull Hook
MDHI Cargo Hook Provisions	Skid Mirror
Onboard Human External Cargo Dual Hook Kit	

INTERIOR

Leather Covered Interior Panels	Right-hand Command Flight Controls
Black Mesh Seats	Right-hand Rotor Brake
28-volt Receptacle	Leather Covered Seats
Pilot/Co-pilot Gooseneck Lights	Night Vision Goggle Compatible Cockpit
USB Charging Ports Cabin and or Cockpit	LED Cockpit/Cabin Lighting
Tilttable or Foldable Monitor Mount	

Additional options may be available for factory installation. Please consult an MDHI Sales Representative about special requirements prior to selection of final configuration.

11 HELICOPTER PERFORMANCE CHARTS

SERVICE CEILING

Maximum operating altitude: Maximum operating density altitude is 16,000 feet.

HOVER CEILING VS GROSS WEIGHT

The hover ceiling vs gross weight charts on the following pages are based on:

- Takeoff power at 100% N2 (high-pressure spool speed)
- Cabin heat and engine anti-ice OFF
- Electrical load of 10 amps
- No wind conditions, or
- Side winds from the right rear quarter



HOVER IN-GROUND EFFECT (HIGE)

The helicopter used in this example has standard landing gear and a standard engine inlet.

Correct use of the Hover Ceiling chart for HIGE.

To determine the maximum gross weight for hovering at 3.5 ft. skid clearance, the pilot must know the pressure altitude (PA) and the OAT.

Example

- **WANTED:** Maximum gross weight for hover at 3.5 feet skid clearance at takeoff power.
- **KNOWN PA** = 8000 feet.
- **KNOWN OAT** = 18°C.
- **WIND** = 17-knot side wind from the right rear quarter.

METHOD: Enter the chart at 18°C on the OAT scale and move up to the 8000 FT pressure altitude line. Move to the right to the controllability limit line and then down to read a hover gross weight capability of **3540 LB**.

NOTE: The maximum internal gross weight is 3350 LB. All weights above 3350 LB must be external and jettisonable.

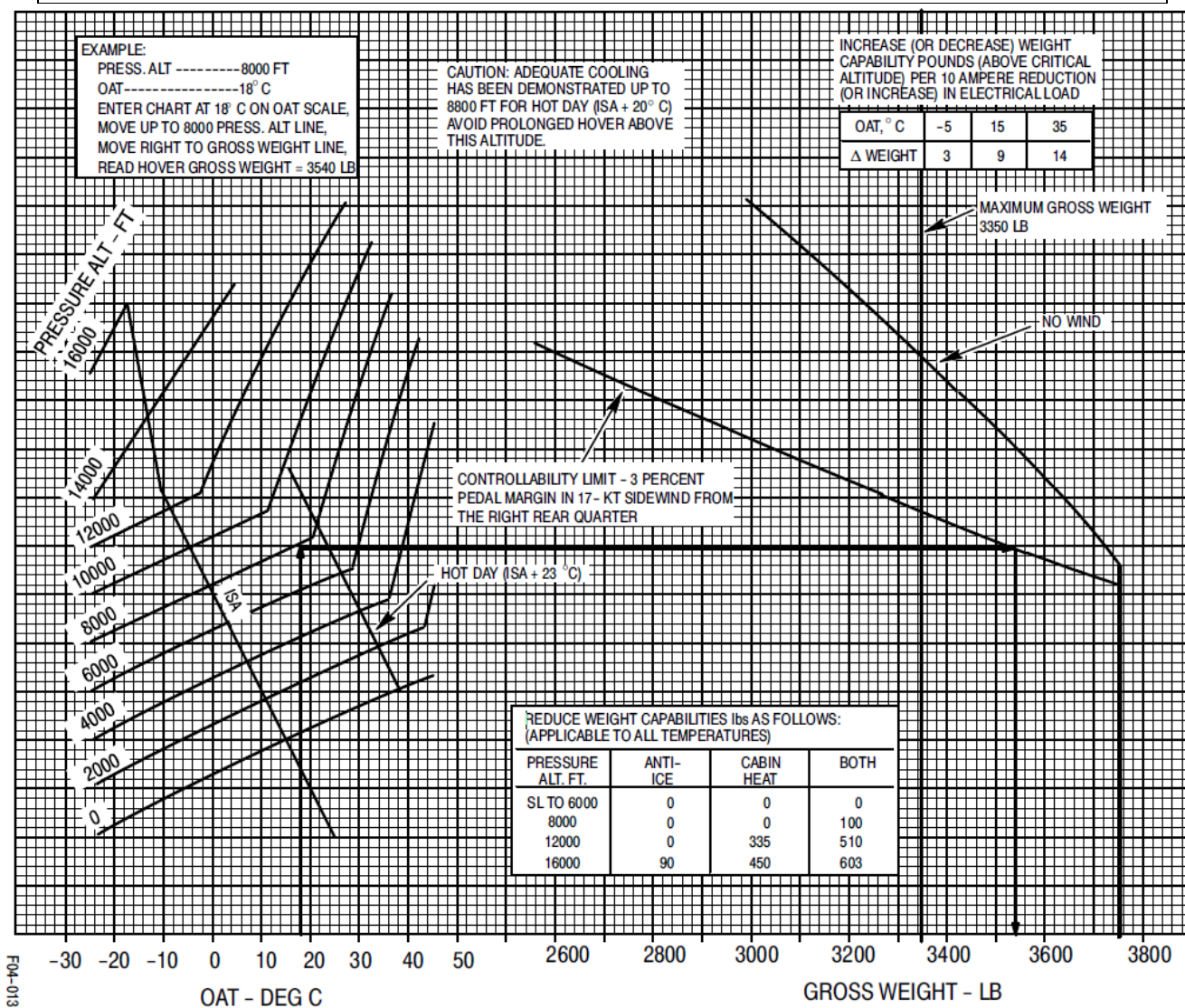

Hover Ceiling, HIGE, 3.5 Foot Skid Clearance, Standard Landing Gear, Standard Engine Inlet

HOVER OUT-OF-GROUND EFFECT (HOGE)

The helicopter used in this example has standard landing gear and a standard engine inlet.

The Hover Ceiling, HOGE, chart shows the maximum hover weight capability, out of ground effect (OGE), at take-off power for known conditions of PA and OAT, or alternately, the maximum hover ceiling for a known gross weight and OAT.

Correct use of the Hover Ceiling chart for HOGE.

To determine the maximum gross weight for hovering at 3.5 ft. skid clearance, the pilot must know the PA and the OAT.

Example

- **WANTED:** Maximum gross weight for hover at 3.5 feet skid clearance at takeoff power.
- **KNOWN PA** = 8000 feet.
- **KNOWN OAT** = 6°C.
- **WIND** = 17-knot side wind from the right rear quarter.

METHOD: Enter the chart at 18°C on the OAT scale and move up to the 8000 FT pressure altitude line. Move to the right to the controllability limit line and then down to read a hover gross weight capability of 3540 LB.

NOTE: The maximum internal gross weight is 3350 LB. All weights above 3350 LB must be external and jettisonable.

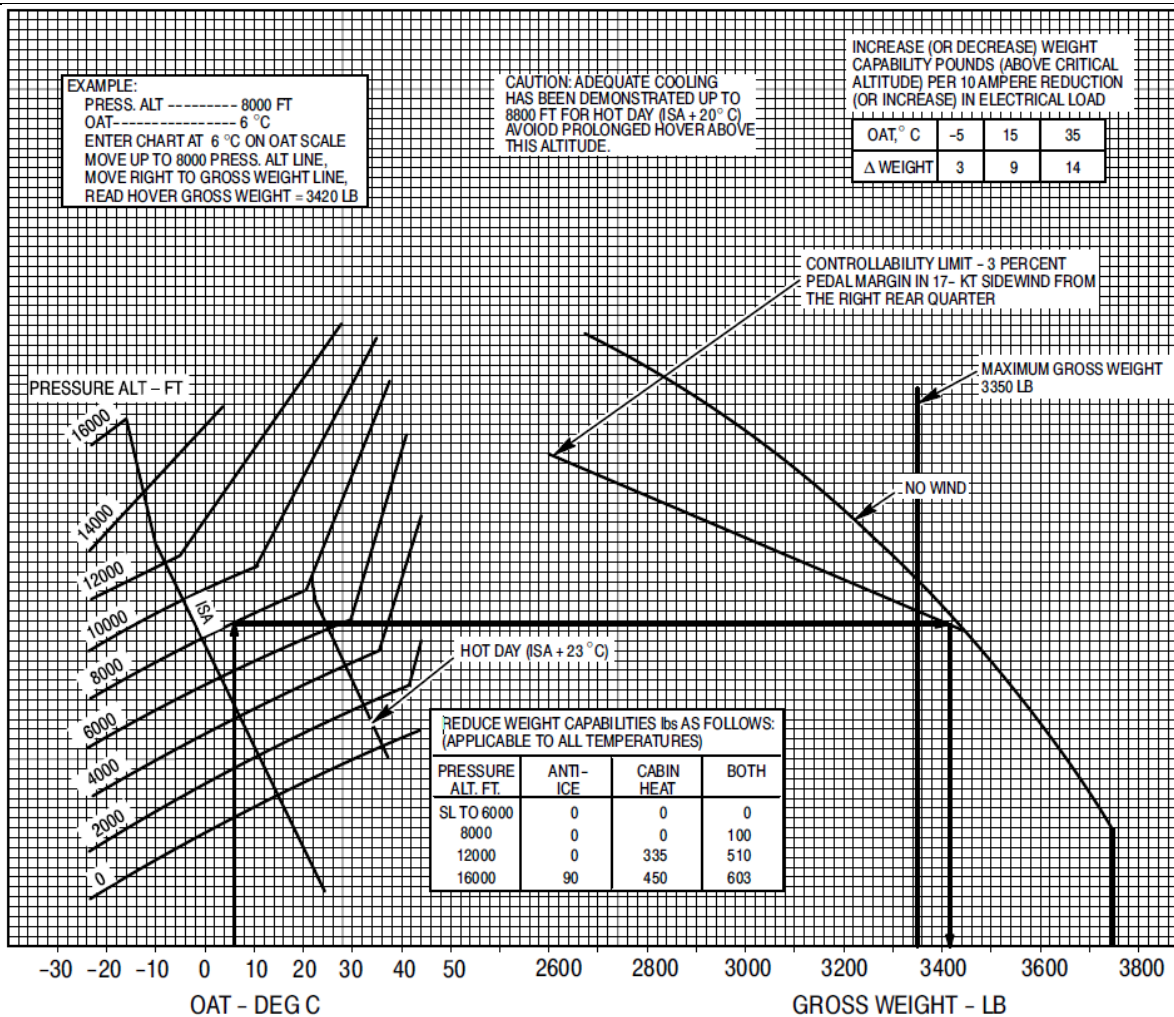

Hover Ceiling, HOGE, Standard Engine Air Inlet

MD 530F FUEL FLOW CONSUMPTION CHARTS

Fuel Flow, Sea Level, ISA (15°C)

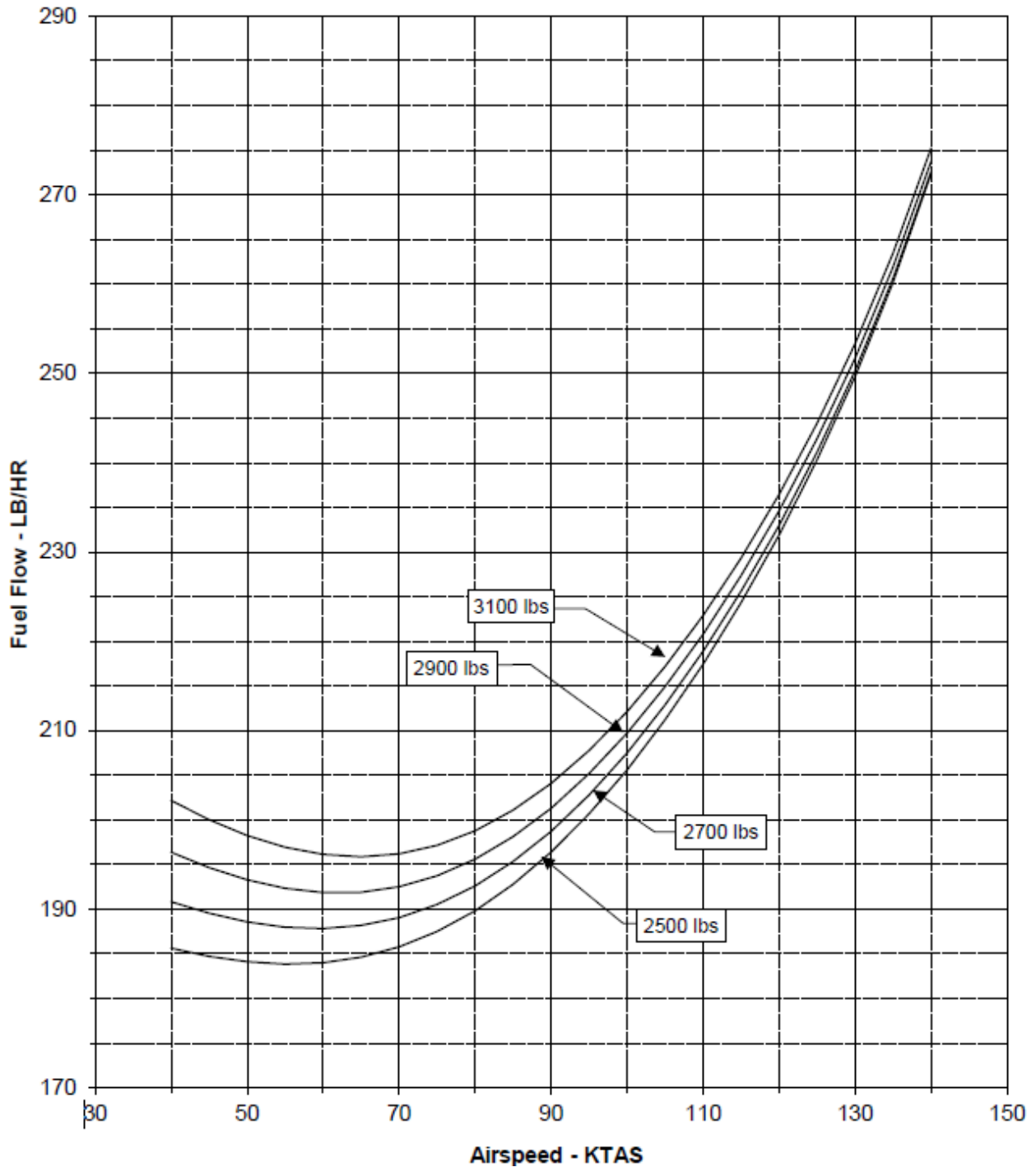

Fuel Flow, Sea Level, ISA + 20°C (35°C)

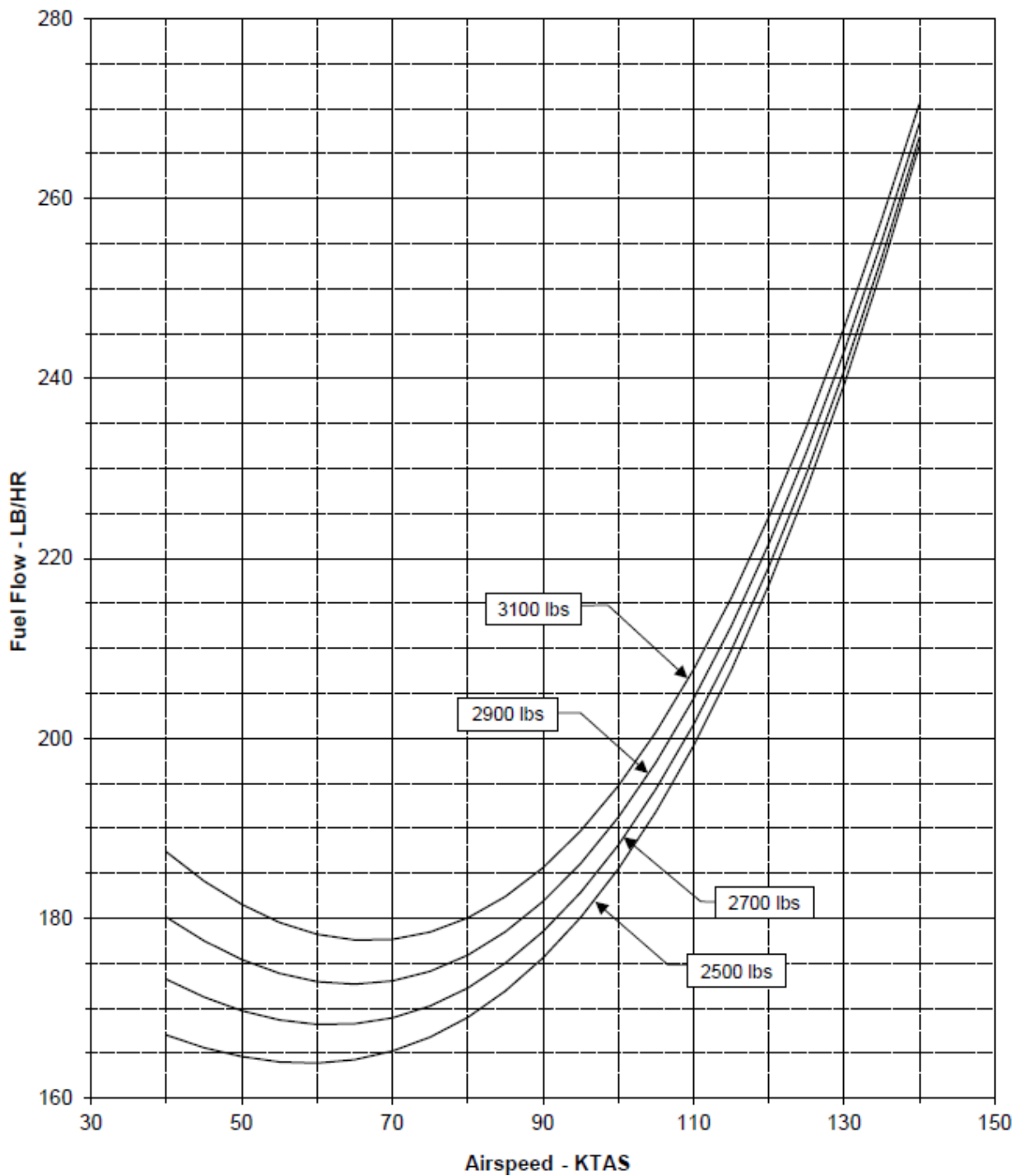

Fuel Flow, 4,000 feet, ISA (7.1°C)

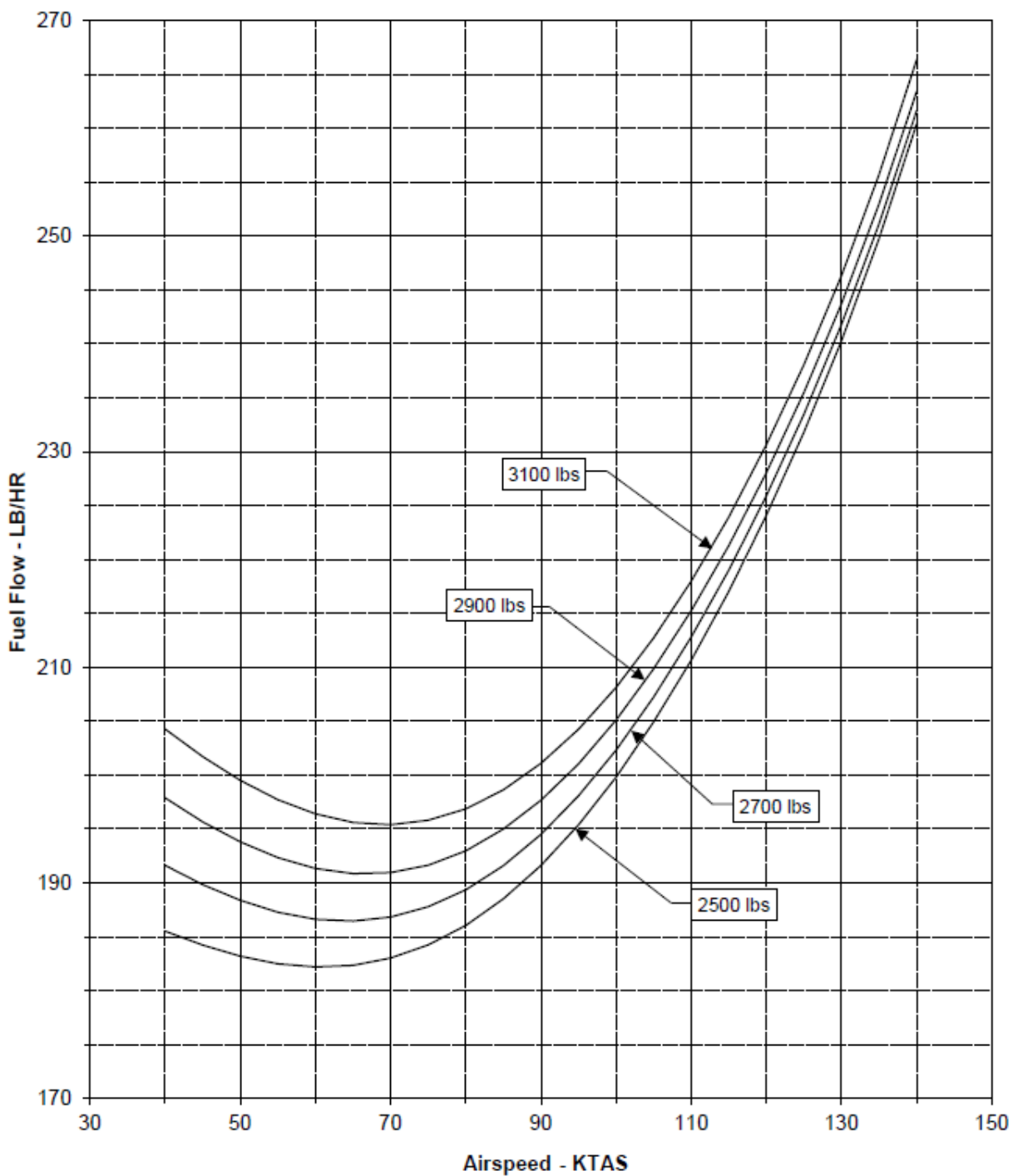

Fuel Flow, 4,000 feet, ISA + 20°C (27.1°C)

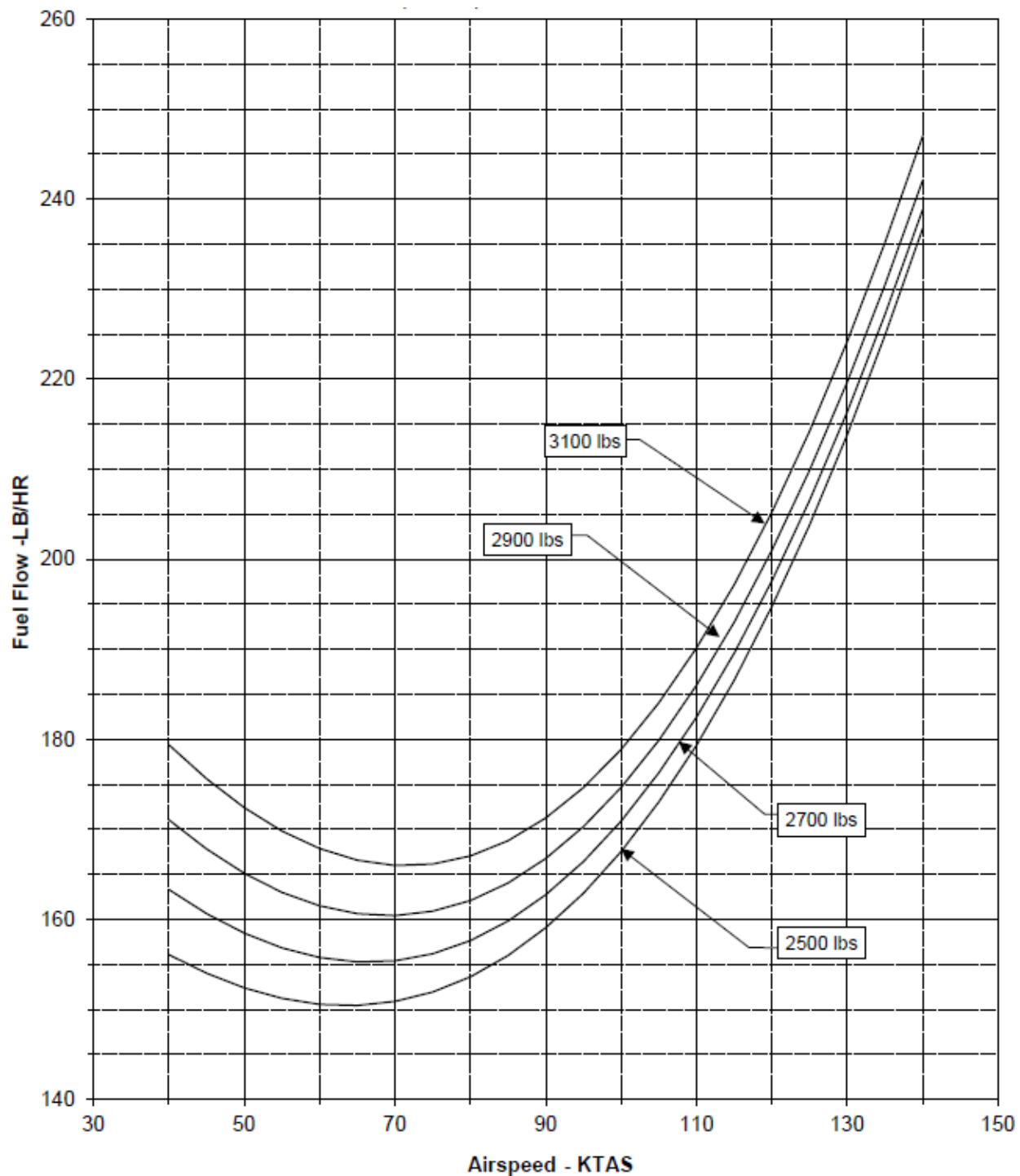

12 COST OF OPERATIONS

INTRODUCTION

The following topics enable review of variables involved in the MD 530F helicopter direct and indirect costs of operation. This data can be applied to calculate a total life estimate for the aircraft based upon how the aircraft is used. Direct operating costs provided below are an average of inputs provided by MDHI’s diverse set of customers:

- Fuel and lubricants
- Basic airframe maintenance
- Engine maintenance

Indirect costs are not directly dependent upon the number of flights and include:

- Insurance
- Facilities (hangar, workshop, etc.)
- Crew compensation
- Financial factors (depreciation, investment tax credit, financing costs, etc.)
- Miscellaneous factors

DIRECT COSTS

<p>Fuel and Lubricants</p>	<p>An average value of fuel and lubricant costs is included in the calculated data provided. Fuel consumption depends upon speed, temperature, externally mounted accessories, sling loads, etc. A band of approximately 10% value will cover these factors for normal operations. Fuel pricing varies considerably based on where the fuel is purchased geographically and whether it is purchased retail or in bulk. The sample cases use average retail purchase prices prevalent at the time the sample data are prepared.</p>
<p>Basic Airframe Maintenance</p>	<p>Airframe maintenance is divided into four categories:</p> <ul style="list-style-type: none"> • Inspections • Overhauls • Replacement of End-of-Life Parts • Unscheduled Maintenance <p>Inspections include proper inspection tasks and part requirements, which are listed in the Maintenance Manual. Man-hours for inspections can vary due to differences in personnel experience, tools, part availability, facilities, and environmental effects such as extremes in working temperatures. Man-hour costs/hour is also variable among the Authorized Service Centers as a result of differences in local costs, overhead expenses, and volume of work. The value used in the calculations is an average of costs per hour at Authorized Service Centers at the time of publication.</p> <p>Overhauls include removal, disassembly, inspection, parts replacement, reassembly and reinstallation of certain components/assemblies at the periods stated in the Maintenance Manual. Overhaul man-hour and parts requirements are subject to considerable variation depending upon the helicopter’s operations and environments.</p> <p>End-of-life parts are those that have reached their respected flight life expectancy and are subjected to disposal after an operating time stated within the Maintenance Manual. These</p>

MD 530F SPECIFICATIONS

	<p>are normally components of the rotors/control systems, which are subject to oscillatory loads and are designed and tested for use over a finite number of flight hours rather than on their condition.</p> <p>Unscheduled maintenance encompasses labor and parts replacement for major maintenance not covered under the formal Maintenance Manual requirements for inspections and overhauls. It also includes those additional maintenance requirements imposed by the manufacturer through issue of Service Bulletins.</p>
Engine Maintenance	<p>The Rolls-Royce engine requires periodic inspection and overhauls. The overhaul periods are based on the number of operating hours or on the number of cycles, whichever is the first limit to be attained. Start cycles are a factor because thermal cycles are important in the design of the turbine engine's rotating components. Overhauls are performed by the engine manufacturer and/or at authorized facilities.</p>

DIRECT OPERATING COST (U.S. Dollars Per Flight Hour)

MD 530F Direct Operating Cost per Hour — Based upon year 2021 \$US	
Fuel and Lubricants ¹	
Fuel @ \$4.26 per gallon @ approximately 35 gallons/ hour Lubricants @ 3% of fuel	\$149105 \$4.47
	\$153.57
Airframe Maintenance and Spares ²	
Maintenance Labor Costs:	
• Scheduled (.39 Man-hours/Flight Hour) @ \$106.00/Hour*	\$41.34
• Unscheduled (.26 Man-hours/Flight Hour) @ \$106.00/Hour*	\$27.56
	\$68.90
Spares Cost:	
• Scheduled (Inspection) Parts: Used during Periodic Inspection i.e., filters, seals, O-rings, etc.	\$5.78
• On-Condition/Unscheduled Part	\$21.12
• Reserves: Component Overhaul (TBO)	\$68.58
• Reserves: Limited Life Parts	\$65.23
	\$160.71
Engine (C30 Engine) ³	
Scheduled maintenance labor & parts	\$3.00
Reserve for engine overhaul, spares and accessories	\$132.26
	\$135.26
Total Direct Operating Cost ⁴	
\$518.44	

Notes:

1 Fuel cost and labor rate* is based on Conklin and de Decker average. Average cost, operating under the following conditions:

- Gross Weight: 10% less than maximum certified
- Speed: Maximum Range Speed, 124 KIAS
- Altitude: 1,000 feet on a standard day

2 Overhaul costs are based on participation in factory exchange program.

3 Engine fleet maintenance costs provided by Rolls-Royce Engine Company.

4 Indirect costs such as insurance, hangar, salary, etc., are excluded.

Cost figures shown are extrapolated from a broad database and are intended for example purposes only. Actual costs will vary, depending on local operating conditions, pricing and supplier practices. We encourage you to compare these figures with other manufacturers, using the same unit costs for fuel, labor, etc.

13 COMPONENT OVERHAUL

SCHEDULED INSPECTION INTERVALS

Scheduled Inspection Intervals		
Inspection	Items	Time to Complete
100 HR	General, interior, exterior, landing gear, cabin, horizontal stabilizer, vertical stabilizer, main rotor, drive train, flight controls, anti-torque system, tail rotor system, electrical, engine compartment, after inspection, post inspection run	22 man-hours
300 HR	Interior, exterior, landing gear, main rotor, drive train, flight controls, anti-torque system, tail rotor system, electrical, engine compartment	32 man-hours
Annually	Exterior, landing gear, cabin, flight controls, electrical, engine compartment	32 man-hours

TIME BETWEEN OVERHAUL (LIMITED LIFETIME PARTS)

Time Between Overhaul		
Component	QTY	Hours
Accessory Gearbox	1	On condition
Blower Belt	1	1,200
Blower Bearings	1	1,200
Starter Generator Overhaul	1	1,200
Bleed Valve Overhaul	1	1,500
Engine Hot Section	1	1,750
Overrun Clutch Overhaul	1	1,800
Governor - Honeywell Overhaul	1	2,000
Fuel Nozzle Overhaul	1	2,500
Fuel Control - Bendix Overhaul	1	2,500
Main Rotor Retention Strap	5	2,770
Main Rotor Swashplate Overhaul	1	2,770
Tail Rotor Transmission Input Shaft	1	3,365
Tail Rotor Transmission Overhaul	1	3,365
Vertical Stabilizer	1	3,388
Main Rotor Blade	5	3,430
Tail Rotor Hub	1	3,450
Fuel Pump	1	2,250
Turbine Overhaul	1	3,500
Main Rotor Transmission Overhaul	1	3,000
Tail Rotor Retention Strap	1	5,100
Tail Rotor Blade	2	5,140
Bolt - Lead Lag Main Rotor	5	6,120

MD 530F SPECIFICATIONS

Time Between Overhaul		
Component	QTY	Hours
Tail Rotor Transmission Output Shaft	1	7,290
Blade Pin	10	7,600
Horizontal Stabilizer	1	7,700
Main Rotor Hub Sub Assembly	1	8,900
Pitch Housing Main Rotor	5	9,100
Compressor Overhaul	1	3,500
Tail Boom Assembly	1	10,300
Mast Assembly Main Rotor	1	10,450
Lead Lag Link Main Rotor	10	11,080
Tail Rotor Drive Shaft	1	14,610
Tail Boom Bolts	4	21,950
Drive Shaft Main Rotor	1	3,410
Drive Shaft, Main Rotor Transmission	1	3,790
Coupling, Main Transmission Drive Shaft	1	4,300
Longitudinal Idler Bell Crank Assembly	1	6,500
Idler Assembly, Longitudinal Pitch Mixer	1	13,600
Main Rotor Hub Assembly Overhaul	1	2,770

NOTE: Airframe is not a Life Limited Component.

14 CUSTOMER SUPPORT AND SERVICES

INTRODUCTION

Hundreds of military and commercial customers around the world rely on MDHI aircraft for their superior reliability, low operating costs, ease of operation, and durability. MDHI’s extensive experience supporting a global fleet with OEM-quality parts and expert technical advice ensures operators maintain the highest levels of operational readiness. MDHI continues to make significant investment in the development and integration of next generation technologies and capabilities, as well as in the design and manufacturing processes necessary to preserve an impeccable reputation and leadership status in the global rotorcraft industry.



Building 610: Production

Building 612: Paint Shop

Building 614:
Warehouse

Building 615:
Administration

Building 620: Completions &
Distribution Center (CDC)

Madison: Composite Shop

Mallory 101 - 105: Training and Aircraft
Maintenance

Aerial View of MD Helicopters, Inc. World Headquarters Main Campus in Mesa, Arizona.

SUPPORT AND SERVICE OFFERINGS

MDHI offers a full range of aftermarket and customer support services that includes comprehensive pilot and maintainer training, a dedicated customer portal for effective fleet management, maintenance tracking and parts and supply ordering, a global network of OEM-authorized/trained service & distribution centers, and 24/7 technical support through highly trained and experienced field service engineers.

MDHI Field Service Engineering

MDHI Field Service Engineering is available to support the global fleet 24/7/365 with the technical expertise and knowledge required to maintain all MDHI model aircraft to factory specifications. The MDHI Field Service Engineering team consists of seasoned FAA and EASA certified airframe and powerplant engineers, all familiar with the intricacies and technical requirements of the entire MDHI product line.

All field service engineers are factory trained. Driven to effectively and efficiently support aircraft sustainment through the full product life cycle, MDHI Field Service Engineering provides the services necessary to support a major repair, or to simply help satisfy a technical issue including:

- SOR / SDR / Fleet data tracking
- Engineered repairs- Major and Minor
- Long-term field service technical support
- Complete support / Maintenance contracts (CLS)
- Certification projects
- Helicopter delivery support - New and Used
- On-site support:
 - Damage evaluations and repairs
 - Airworthiness inspections
 - Aircraft modifications

Spares, Replacement Parts and Accessories

MDHI and its Authorized Service Center/Distributor network work together to ensure timely sustainability of the global MDHI fleet. Through this network, customers have access to a global inventory of parts.

Overhaul and Repair

MDHI overhauls all helicopter components in our Part 145 Maintenance Repair & Overhaul facility.

• Main rotor hubs (single engine)	• Starter generators
• Main transmissions	• Fire bottles (twin engine)
• Certified single engine transmission test stand (single engine)	• Hydraulic pump (twin engine)
• Tail rotor transmissions (single engine)	• Detent module (twin engine)
• Overrunning clutches (single engine)	

MyMD.aero™

MyMD.aero™ is a user-driven, web-based secure network portal designed to modernize and improve maintenance planning, parts availability and communication for MDHI helicopter operators worldwide. MyMD.aero™ provides a single source for managing fleet data, aircraft maintenance, locating global inventory, requesting quotations for service or upgrades, and accessing technical publications. Membership based, the network portal is open to all MDHI-brand helicopter owners, operators, authorized service centers, and authorized distributors.

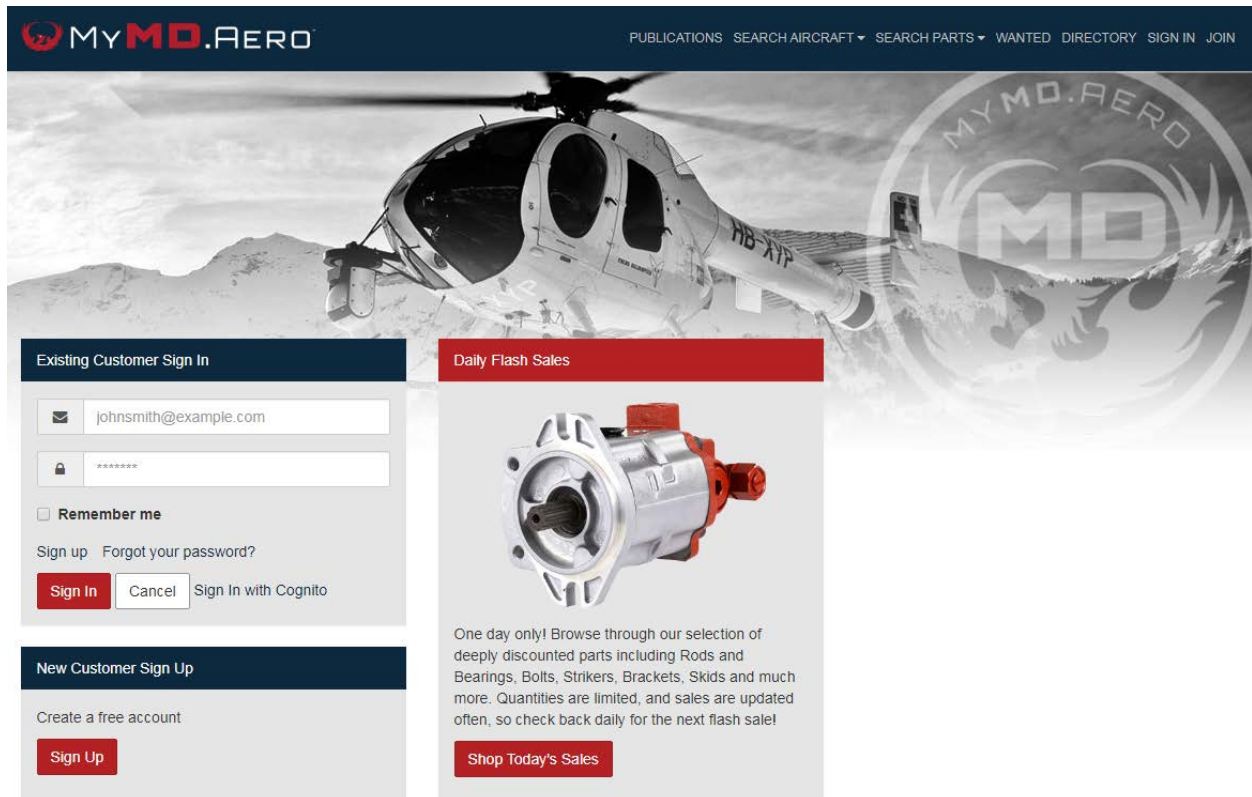

MyMD.aero™. Designed to reduce workload and increase efficiencies for global MD helicopter operators.

Accessible from any mobile or desktop device anywhere in the world, MyMD.aero™ is beneficial to all the key players in the ongoing operation of the growing, global MDHI family:

- **Operators:** MyMD.aero™ is an easy-to-use tool for updating and maintaining accurate usage data for their aircraft or fleet.
- **Service Centers:** MyMD.aero™ provides a singular platform for facilitating the exchange of information between service centers, operators, maintainers and OEM field service and support teams.
- **Maintenance Planners:** MyMD.aero™ provides an easy and efficient way to track and plan maintenance on MDHI aircraft worldwide.

AUTHORIZED SERVICE CENTERS

MD Helicopters, Inc. has Authorized Service Centers located worldwide. Detailed service center information is available from the “Support” page of the MDHI website, mdhelicopters.com.

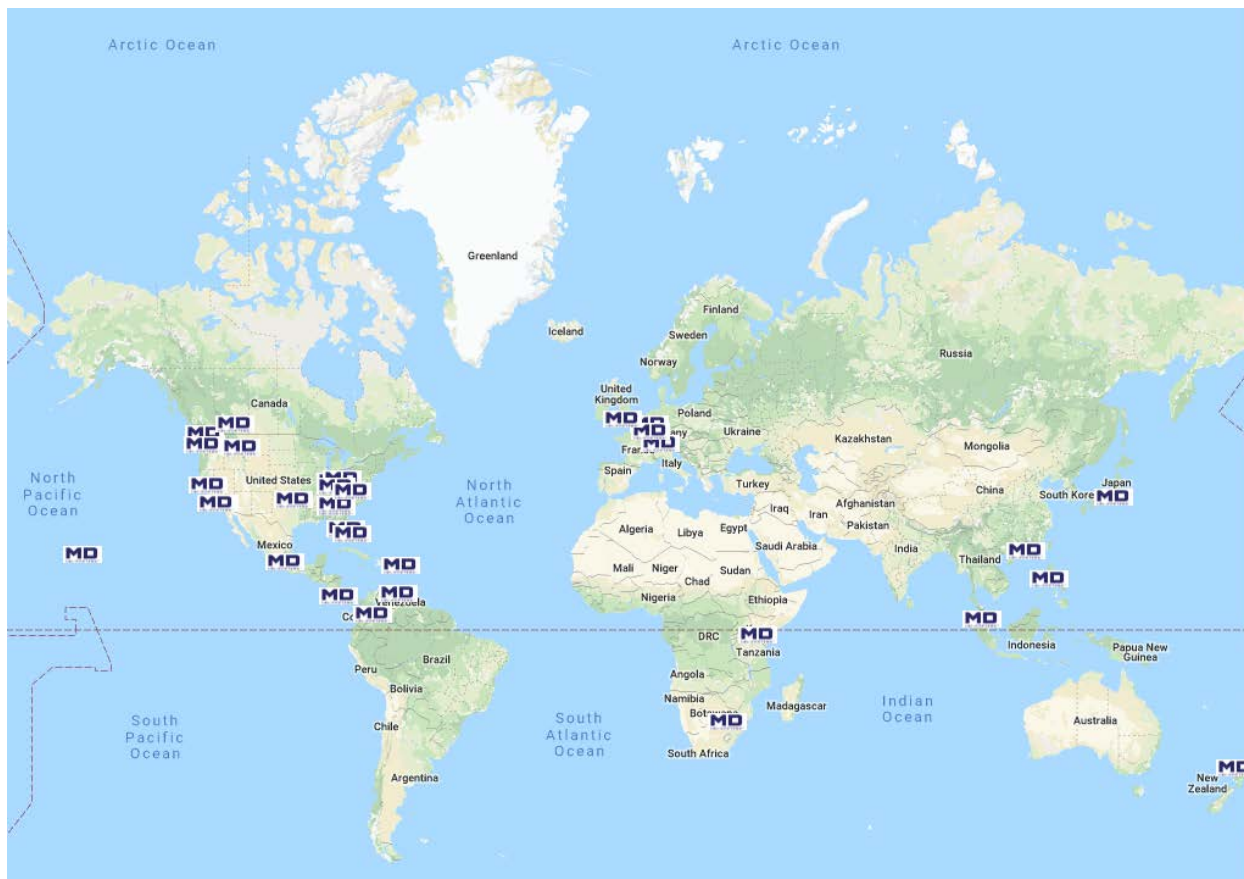

DISTRIBUTOR OF SPARE PARTS

Authorized spare part Distribution Centers are located across four regions globally. Detailed distribution center information is available from the “Support” page of the MDHI website, mdhelicopters.com.



WARRANTY / WARRANTY CLAIMS

MDHI is committed to manufacturing and delivering quality aircraft. All products are backed by one of the most comprehensive limited warranties in the industry. The two-year or 2,000-hours limited warranty that is standard on all new aircraft purchases demonstrates MDHI's unwavering confidence in the design, manufacture and support of its products. MDHI also provides a Component Exchange Program designed to assist the helicopter owner by giving access to major components at prices significantly lower than the prices of new components. This program can reduce overall costs and keep downtime to a minimum.

All MDHI warranty and exchange programs are supported by a comprehensive network of factory-Authorized Service Centers. These locations provide factory inspected and approved parts, as well as expert service, for all MDHI products. The MD 530F commercial helicopters are covered by a commercial warranty, which is administered by MD Helicopters, Inc. in Mesa, Arizona. The limited commercial warranty (CSP-A-2) can be viewed from the "Support/Warranty" page of the MDHI website, mdhelicopters.com. Click on *Warranty & Exchange Program Information (CSP-A-2)* to view.

The MDHI Commercial Warranty is a materials and workmanship type warranty that begins upon customer helicopter / spare parts acceptance / delivery. The customer will perform prompt repair or replacement of helicopter-specific discrepant hardware. For warranty claims pertaining to aftermarket spare parts and components, the customer, at their option (with prior approval), either:

- Returns the non-conforming or defective part or component for credit or refund; or
- Requests correction or replacement of the affected part or component. Associated shipping costs shall be shared by the customer and the vendor.

All warranty claims begin with completion of an MDHI Service and Operations Report (SOR) document, which can be accessed via the MyMD.aero™ portal.

Supplier products (e.g., turboshaft engine, avionics, etc.) are warranted separately through the product supplier. Visit the product OEM website, or contact the OEM directly, for details on specific product warranties.

15 MDHI TRAINING ACADEMY

INTRODUCTION

MDHI is committed to providing industry-leading maintenance and pilot familiarization training to all customers in a professional learning environment. The MD 530F's structural design, exceptional visibility, simple controls, and ruggedness make it a fantastic training aircraft.

The MDHI Training Academy provides industry-leading maintenance and pilot training to all customers in a professional learning environment. Offerings include a comprehensive portfolio focused on mission execution, effectiveness and safety. Training for one (1) pilot and one (1) mechanic is included at no charge for each aircraft purchased. Training for additional pilots and mechanics, as needed, is available.

TRAINING COURSES

Pilot Training Completion Standards

MDHI flight training does not give a customer a new aviator's certificate or rating. Pilot competence is based on meeting the requirements outlined in the Practical Test Standards for the type of rating held. Pilots who successfully complete both ground and flight instruction will receive a Certificate of Completion for the course attended.



Pilot Training Requirements

Before transition or recurrent training begins, customers must provide proof of the following:

1. A valid helicopter rating (minimum of a private rotorcraft rating) and current medical certificate.
2. A signed, hold harmless statement.



Maintenance Training Courses

The maintenance courses are designed for FAA/repair station certified mechanics, but are open to all customers. Courses are conducted in English. If customers are not fluent in English, a special course of longer duration must be scheduled four (4) months prior to training date, with a translator provided by the customer. This longer course will entail an additional cost. A translator will not be allowed in an English-speaking class.





2019 CUSTOMER TRAINING

2019 PILOT TRAINING COURSES

Duration

Transition Training: 16 hours of ground school & up to 5 hours of flight time

500 Series 5 days

600N 5 days

Explorer 5 days

Interpreted Transition – (adds 1 week) 10 days

Recurrent Training: 8 hours of ground school & up to 3 hours of flight time

500 Series 3 days

600N 3 days

Explorer 3 days

Differences Training: 5 hours of ground school & up to 3 hours of flight time

530F/520N 3 days

Maintenance Test Flight Procedures: 8 hours of ground school & up to 3 hours of flight time

500/600 3 days

Explorer 3 days

Night Emergency Procedures: 3 hours of ground school & up to 2 hours of flight

500 Series 2 days

Flight training rates for additional flight time, or when not enrolled in an MDHI course:

MD 500 Series

MD 600N

MD Explorer

2019 MAINTENANCE TRAINING COURSES

Duration

500 D/E 2 weeks

530 FF 2 weeks

520 N 2 weeks

600N 2 weeks

Explorer 2 weeks

Interpreted 500D/E, 530FF, 520N, 600N, Explorer 3 weeks

500 Maintenance Refresher Training 3 days

500 N Differences Training 1 week

Explorer Auto Pilot 3 days

Interpreted 1 week

Transmission Overhaul 500 D/E/FF 1 week

OFF-SITE Training Day

Off-site training will be priced on an "as requested" basis, based on the specifics of that training. Pricing includes flights, hotel, transportation and per diem.

GENERAL INFORMATION / TERMS AND CONDITIONS

- The training day is from 8 a.m. to 3:00 p.m. Mountain Time (MT) in Arizona, including a one-hour lunch break.
- Courses are conducted in English. If students are not fluent in English, a special course of longer duration must be scheduled four (4) months prior to the training date, with a translator provided by the student. This longer course will entail an additional cost.
- A translator will not be allowed in an English-speaking class.
- Students must be available for instruction through the entire day of the last day scheduled for course.
- Failure to schedule departure after 5 p.m. on the course end date may interfere with completion of scheduled training.
- Courses may be cancelled and customers rescheduled due to insufficient enrollment.
- If a course you are registered for is cancelled, you will be notified in writing and registered for the next available course.
- MDHI accepts credit card payments (VISA/MasterCard/American Express), check, or cashier's check/money order. Cash is not an acceptable payment option.
- A 10% deposit is required at the time of confirmation of scheduled training.
- Deposit will be forfeited if the student fails to cancel twenty (20) days prior to the start of the scheduled course, or is not present on the first day.
- Tuition is required to be paid in full before to the first day of the course.
- Only students who provide a purchase order or who have a current open account with MD Helicopters, Inc. will be billed after training.
- Course prices are subject to change without notice.
- Comprehensive training manuals are provided on the first day of the course only to customers registered for one of our training courses.
- Manuals are not sold separately by the Training Department or through the Technical Publications Department.

ABBREVIATIONS, ACRONYMS AND SYMBOLS

ADAHRS	Air Data Attitude and Heading Reference System
ADS-B	Automatic Dependent Surveillance-Broadcast
AFS	Aerospace Filtration Systems, Inc.
Amp	Ampere
ASQ	Auto Squelch
BSN	Blue Sky Network
BMS	Broadcast Microwave Services, Inc.
°C	Centigrade
CDC	Completions & Distribution Center
CFR	Code of Federal Regulations
CLS	Contract Logistics Support
cm	Centimeter
CMU	Configuration Module Unit
COMM	Communication
DAU	Data Acquisition Unit
EASA	European Union Aviation Safety Agency
EFIS	Electronic Flight Instrument System
EICAS	Engine Indicating and Crew Alerting System
EIUs	Engine Instrument Units
ELT	Emergency Locator Transmitter
ES	Extended Squitter
FAA	Federal Aviation Administration
ft	Feet
<i>g</i>	Gravitational Force
gal	Gallon
GPS	Global Positioning System
HDU	Howell Display Unit
HIGE	Hover In-Ground Effect
HOGE	Hover Out-Of-Ground Effect
hr / hrs	Hour / Hours
HTAWS	Helicopter Terrain Awareness and Warning System
ICS	Intercom System
IFR	Instrument Flight Rules
ISA	International Standard Atmosphere
kg	Kilogram
km	Kilometer
kW	KiloWatt
lb / lbs	Pound / Pounds

MD 530F SPECIFICATIONS

LCD	Liquid Crystal Display
m	Meter
MDHI	MD Helicopters, Inc.
MFD	Multi-Function Displays
MHz	Megahertz
mi	Miles
min	Minute
mph	Miles Per Hour
N2	High-pressure Spool Speed
NAV	Navigation
NVG	Night Vision Goggles
NVIS	Night Vision Imaging System
OAT	Outside Air Temperature
OEM	Original Equipment Manufacturer
OGE	Out Of Ground Effect
OTAR	Over-The-Air Rekeying
PA	Pressure Altitude
PFD	Primary Flight Displays
REV	Reversionary
SA	Situational Awareness
SATCOM	Satellite Communication
sec	Second
SDR	Service Difficulty Report
shp	Shaft Horsepower
SOR	Service and Operations Report
STA	Station
SynVis	Synthetic Vision
USB	Universal Serial Bus
VFR	Visual Flight Rules
VIP	Very Important Person
V _{NE}	Velocity, Never Exceed
VMC	Visual Meteorological Conditions
WAAS	Wide Area Augmentation System
WOG	Weight On Ground
%	Percent



MD HELICOPTERS™
MADE IN AMERICA

4555 EAST MCDOWELL ROAD | MESA, AZ 85215 USA
P 1.480.346.6300 | P 1.800.388.3378

 | MDHELICOPTERS.COM

